

Gear Pumps / Motors

Series PGP / PGM
Fixed Displacement Pumps,
Cast-Iron and Aluminium Designs

aerospace
climate control
electromechanical
filtration
fluid & gas handling
hydraulics
pneumatics
process control
sealing & shielding



ENGINEERING YOUR SUCCESS.

Contents

Contents	Page
PGP/PGM500 Characteristics	3
PGP502 Ordering Code	4
PGP502 Performance curves	5
PGP502 Technical Data / Dimensions	6
PGP505 Ordering Code	7
PGP505 Performance curves	8
PGP505 Technical Data / Dimensions	9
PGP/PGM511 Ordering Code	11
PGP511 Operating Conditions	12
PGP511 Performance curves	13
PGP511 Technical Data / Dimensions	14
PGM511 Technical Data / Dimensions	17
PGP517 Ordering Code	18
PGP517 Operating Conditions	19
PGP517 Performance curves	20
PGP517 Technical Data / Dimensions	21
PGP500 Ordering Example (Multiple Pumps)	23
PGP/PGM600 Characteristics	24
PGP/PGM620 Ordering Code	25
PGP620 Performance Curves	26
PGP620 Technical Data / Dimensions	27
PGP/PGM640 Ordering Code	29
PGP640 Performance Curves	30
PGP640 Technical Data / Dimensions	31
PGP600 Ordering Example (Multiple Pumps)	32
Split Gear Pumps	33
Nomograph	34
Nomograph for Pipe Velocity	34
Shaft Loads / Fluids	35

 **WARNING**

FAILURE OR IMPROPER SELECTION OR IMPROPER USE OF THE PRODUCTS AND/OR SYSTEMS DESCRIBED HEREIN OR RELATED ITEMS CAN CAUSE DEATH, PERSONAL INJURY AND PROPERTY DAMAGE.

This document and other information from Parker Hannifin Corporation, its subsidiaries and authorized distributors provide product and/or system options for further investigation by users having technical expertise. It is important that you analyze all aspects of your application, including consequences of any failure, and review the information concerning the product or system in the current product catalogue. Due to the variety of operating conditions and applications for these products or systems, the user, through its own analysis and testing, is solely responsible for making the final selection of the products and systems and assuring that all performance, safety and warning requirements of the application are met.

The products described herein, including without limitation, product features, specifications, designs, availability and pricing, are subject to change by Parker Hannifin Corporation and its subsidiaries at any time without notice.

Offer of Sale

Please contact your Parker representation for a detailed "Offer of Sale".

PGP 500 pumps offer superior performance, high efficiency and low noise operation at high operating pressures. They are produced in four frame sizes (PGP 502, PGP 505, PGP 511, PGP 517) with displacements ranging from 0.8 to 70 cm³/rev. A wide variety of standard options is available to meet specific application requirements.



Characteristics

- **Up to 280 bar continuous operation**
High strength materials and large journal diameters provide low bearing loads for high pressure operation.
- **Low noise**
PGP 502 - 9 tooth gear profile, PGP 505 and 517 - 13 tooth gear profile, PGP 511 - 12 tooth gear profile and optimized flow metering provide reduced pressure pulsation and exceptionally quiet operation (PGP511 also available as noise reduced “stealth” version).

- **High efficiency**
Pressure balanced bearing blocks assure maximum efficiency under all operating conditions.
- **Application flexibility**
International mounts and connections, integrated valve capabilities and common inlet multiple pump configurations provide unmatched design and application versatility.
- **Large range of integrated valves**

Technical data

Pump type	Heavy-duty, aluminium, external gear.
Mounting	SAE, rectangular, thru-bolt standard specials on request.
Ports	SAE and metric split flanges and others
Shaft style	SAE splined, keyed, tapered, cylindrical tang drive, specials on request.
Speed	500 - 5000 rpm, see Technical Data
Theor. displacement	See Technical Data
Drive	Drive direct with flexible coupling is recommended.
Axial / Radial load	Units subject to axial or radial loads must be specified with an outboard bearing.
Inlet pressure	Operating range 0.8 to 2 bar abs. Min. inlet pressure 0.5 bar abs. Short time without load. Consultation is recommended.
Outlet pressure	See Technical Data
Pressure rising rate	Max. 3000 bar/s
Flow velocity	See Nomograph for Pipe Velocity
Hydraulic fluids	Hydraulic oil HLP, DIN 51524-2
Fluid temperature	Range of operating temperature -15 to +80 °C. Max. permissible operating pressure dependent on fluid temperature. Temperature for cold start -20 to -15 °C at speed ≤ 1500 rpm. Max. permissible operating pressure dependent on fluid temperature.

Fluid viscosity	Range of operating viscosity 8 to 1000 mm ² /s (511 & 517) 20 to 1000 mm ² /s (502 & 505) Max. permissible operating pressure dependent on viscosity. Viscosity range for cold start 1000 to 2000 mm ² /s at operating pressure p ≤ 10 bar and speed n ≤ 1500 rpm.
Range of ambient temperature	-40 °C to +70 °C
Filtration	According to ISO 4406 Cl. 18/16/13
Direction of rotation (looking at the drive shaft)	Clockwise, counter-clockwise or double. Attention! Drive pump only in indicated direction of rotation.
Multiple pump assemblies	<ul style="list-style-type: none"> • Available in two or three section configuration. • Max. shaft load must be conform to the limitations shown in the shaft loading rating table in this catalogue. • Max. load is determined by adding the torque values for each pumping section that will be simultaneously loaded.
Separate or common inlet capability	Separate inlet configuration: <ul style="list-style-type: none"> • Each gear housing has individual inlet and outlet ports. Common inlet configuration: <ul style="list-style-type: none"> • Two gear sets share a common inlet.

PI PGP-PGM UK.PMD RH





Gear design

Type

502

Unit

**Dis-
placement**

Rotation

Shaft

Flange

Shaft seal

Inlet side ports option

Outlet

No rear ports
(rear ports on request)

B 1 B 1

Code	Type
P	Pump

Code	Unit
	Pump
A	Single unit
B	Multiple unit

Displacement	
Code	ccm
0008	0.8
0012	1.2
0016	1.6
0021	2.1
0025	2.5
0033	3.3
0036	3.6
0043	4.3
0048	4.8
0058	5.8
0062	6.2
0079	7.9

Code	Rotation
C	Clockwise
A	Counter-clockwise

Code	Shaft
H1 ²⁾	Ø10, 3.0 key, no thread, 36L, parallel
P2 ³⁾	Ø9.35, 8.8L, 2.4 key, M6, taper 1:8
V1 ⁴⁾	5x6.5 long shaft w/o coupling tang drive
V2 ⁵⁾	5x4.5 short shaft w/o coupling tang drive

Code	Port options
E3E2	1/2" - 14 BSP thread/ 3/8" - 19 BSP thread
J4J3	Ø12 mm - Ø30 mm - M6 square flange/ Ø8 mm - Ø30 mm - M6 square flange

Example: E3 = inlet port
E2 = outlet port

Code	Shaft seal
X	No seal
N	NBR

Code	Flange
D1	52.2x72.0 - Ø25.4 rectangular
H1	82.5 - Ø50.8 SAE "A-A" 2 bolt flange
P3	40.0x40.0 - Ø32.0 w/ seal, thrubolt flange
P4	40.0x40.0 - Ø32.0 w/ seal f. short shaft, thrubolt flange

²⁾ Only used with flange H1, D1.

³⁾ Only used with flange D1.

⁴⁾ Only used with flange H1.

⁵⁾ Only used with flange P3, P4.

PGP502 - 0.8 CC

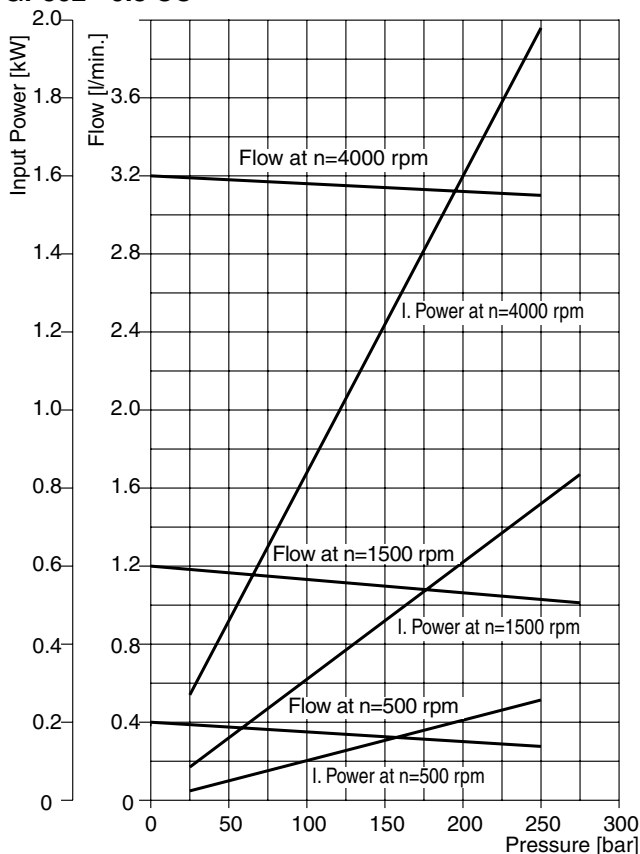

PGP502 - 2.1 CC

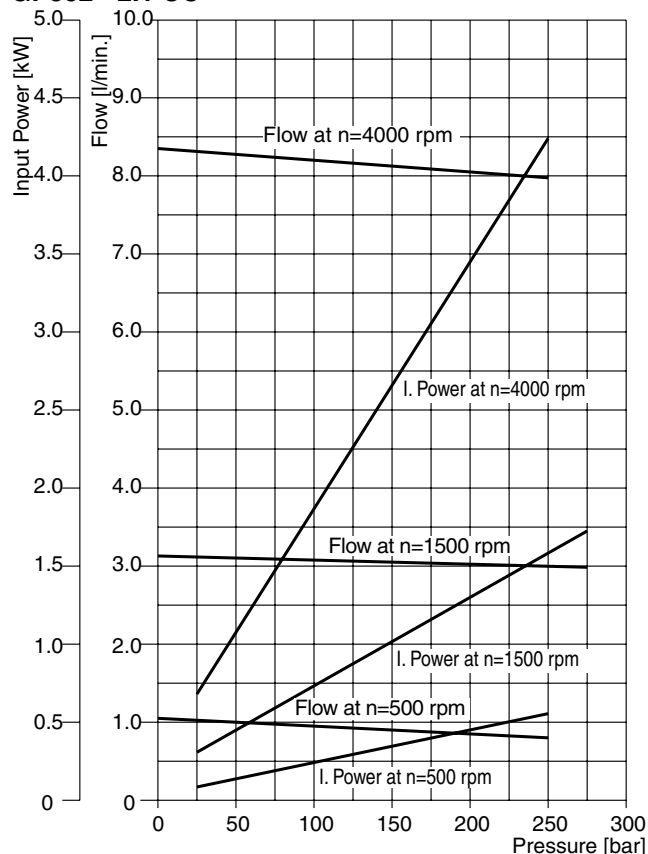

PGP502 - 3.6 CC

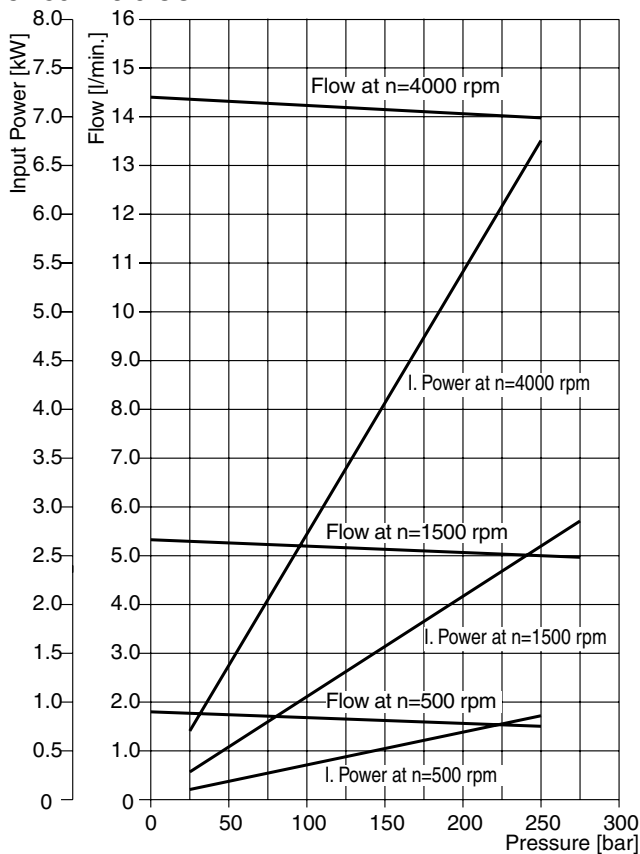

PGP502 - 6.2 CC

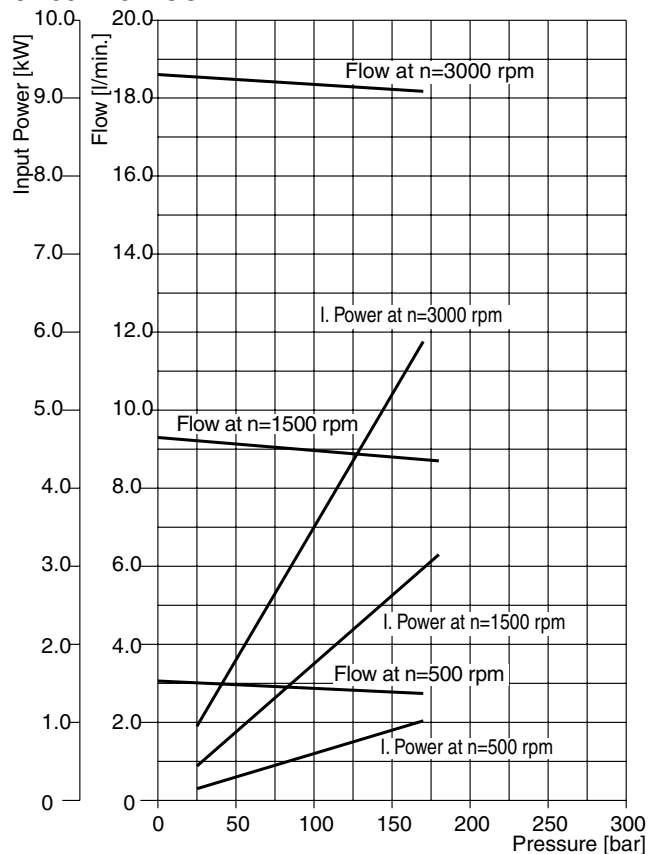

PI PGP-PGM UK.PMD RH

Fluid temperature: 45 °C ± 2K ; Viscosity: 36mm²/s ;

Inlet pressure: 0.9 + 0.1 bar absolute



PGP502 A XXXX Y P2 D1 N SS PP B1 B1

“Y” = C (clockwise rotation)
 = A (counter-clockwise rotation)

Displacement XXXX	cm ³ /rev	Dimension			Inlet port			Outlet port			Speed of rotation		Working pressure max. bar	Order number direction of rotation	
		A mm	B mm	C mm	SS	G mm	F mm	PP	G mm	F mm	min. rpm	max. rpm		clockwise	counter- clockwise
0008	0.8	32.6	65.3	94.0	E3	G 1/2"	33	E2	G 3/8"	24	500	5000	280	330 9111 346	330 9112 233
0012	1.2	33.4	66.8	96.0	E3	G 1/2"	33	E2	G 3/8"	24	500	5000	280	330 9111 347	330 9112 234
0016	1.6	34.1	68.3	97.5	E3	G 1/2"	33	E2	G 3/8"	24	500	5000	280	330 9111 348	330 9112 235
0021	2.1	34.9	69.9	99.0	E3	G 1/2"	33	E2	G 3/8"	24	500	4500	280	330 9111 349	
0025	2.5	35.7	71.5	100.5	E3	G 1/2"	33	E2	G 3/8"	24	500	4500	280	330 9111 350	330 9112 236
0033	3.3	37.2	74.5	103.5	E3	G 1/2"	33	E2	G 3/8"	24	500	4000	280	330 9111 351	330 9112 237
0036	3.6	37.8	75.6	104.5	E3	G 1/2"	33	E2	G 3/8"	24	500	4000	260	330 9111 352	330 9112 238
0043	4.3	39.2	78.5	107.5	E3	G 1/2"	33	E2	G 3/8"	24	500	4000	250	330 9111 353	
0048	4.8	40.0	80.0	109.0	E3	G 1/2"	33	E2	G 3/8"	24	500	3800	230	330 9111 354	330 9112 239
0058	5.8	41.9	83.8	113.0	E3	G 1/2"	33	E2	G 3/8"	24	500	3800	200	330 9111 355	330 9112 240
0062	6.2	42.6	85.3	114.5	E3	G 1/2"	33	E2	G 3/8"	24	500	3500	180	330 9111 356	330 9112 241
0079	7.9	45.8	91.6	121.0	E3	G 1/2"	33	E2	G 3/8"	24	500	3000	160	330 9111 357	

Dimensions (clockwise rotation shown)

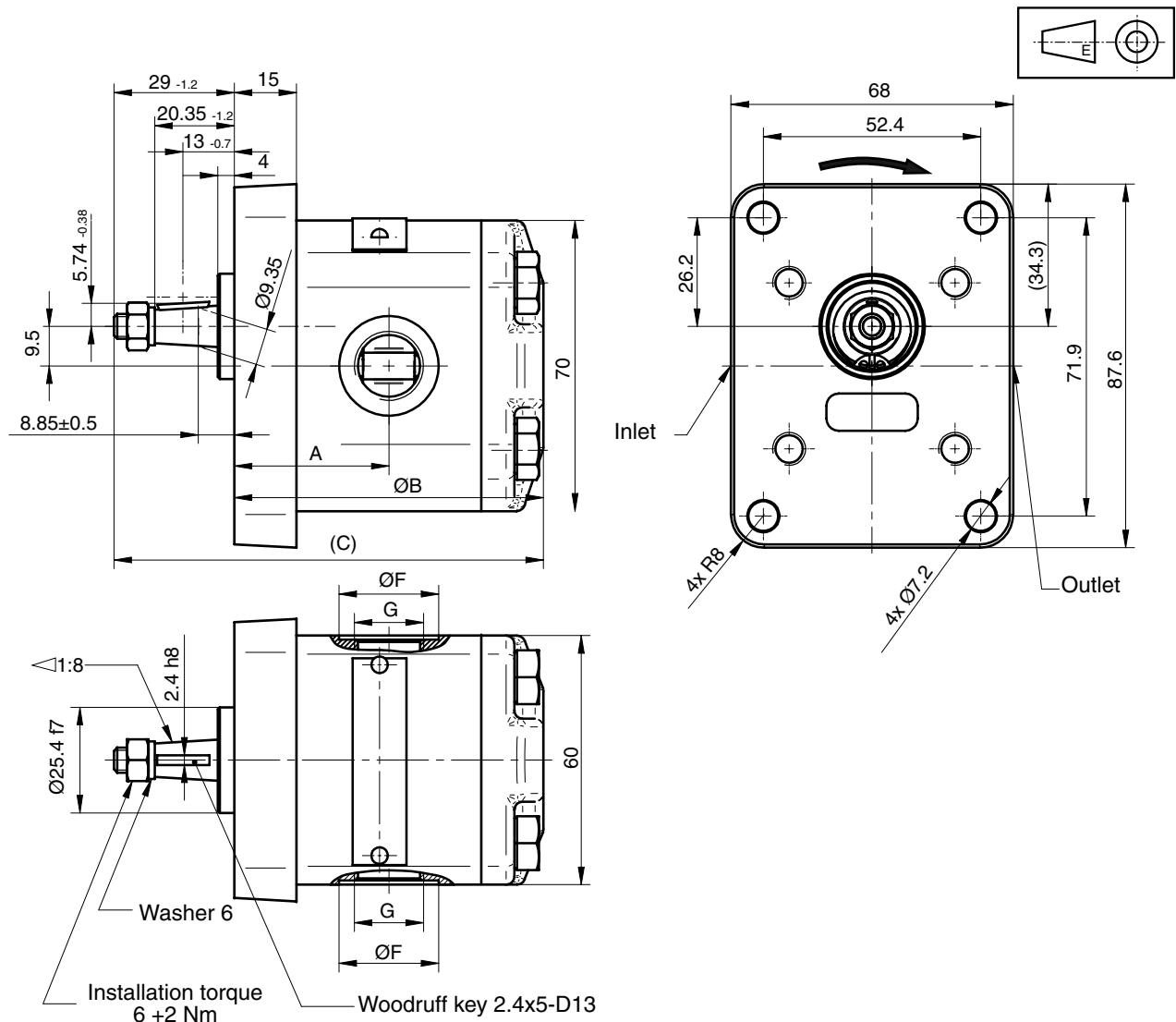

PI PGP-PGM UK.PMD RH





PG
 Gear design

Type

505

Unit

Displacement

Rotation

Shaft

Flange

Shaft seal

Inlet side ports

Outlet side ports

B 1 B 1

No rear ports
 (rear ports on request)

Code	Type
P	Pump

Code	Unit Pump
A	Single unit
M	Single distributor unit
B	Multiple unit

Displacement	
Code	ccm
0030	3.0
0040	4.0
0060	6.0
0080	8.0
0100	10.0
0120	12.0

Code	Rotation
C	Clockwise
A	Counter-clockwise

Code	Shaft
A1 ²⁾	9T, 16/32DP, 32L, SAE "A" spline
J1 ²⁾	Ø12.7, 3.2 key, no thread, 38L, parallel
K1 ³⁾	Ø15.88, 4.0 key, no thread, 32L, SAE "A", parallel
Q2 ⁴⁾	Ø14.25, 5.5L, 3.0key, M10x1, taper 1:8

Code	Port options
E5E3	3/4" - 14 BSP thread/ 1/2" - 14 BSP thread
J7J5	Ø20 mm - Ø40 mm - M6 square flange/ Ø15 mm - Ø35 mm - M6 square flange

Example: J7 = inlet port
 J5 = outlet port

Code	Shaft seal
X	No seal
N	NBR

Code	Flange
D2 ⁵⁾	56.0x73.0 - Ø30.0 rectangular
H1	82.5 - Ø50.8 SAE "A-A" 2 bolt flange
H2 ⁶⁾	106.4 - Ø82.55 SAE "A" 2 bolt flange

⁵⁾ Only used with ports J*J*.
⁶⁾ Only used with ports E*E*.

²⁾ Only used with flange H1, H2.
³⁾ Only used with flange H2.
⁴⁾ Only used with flange D2.

PGP505 - 3.0 CC

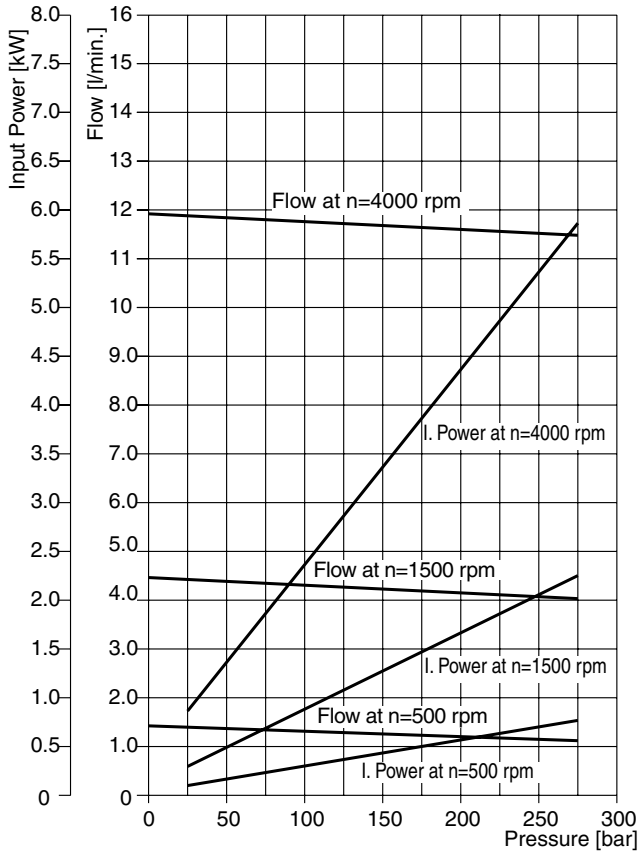

PGP505 - 6.0 CC

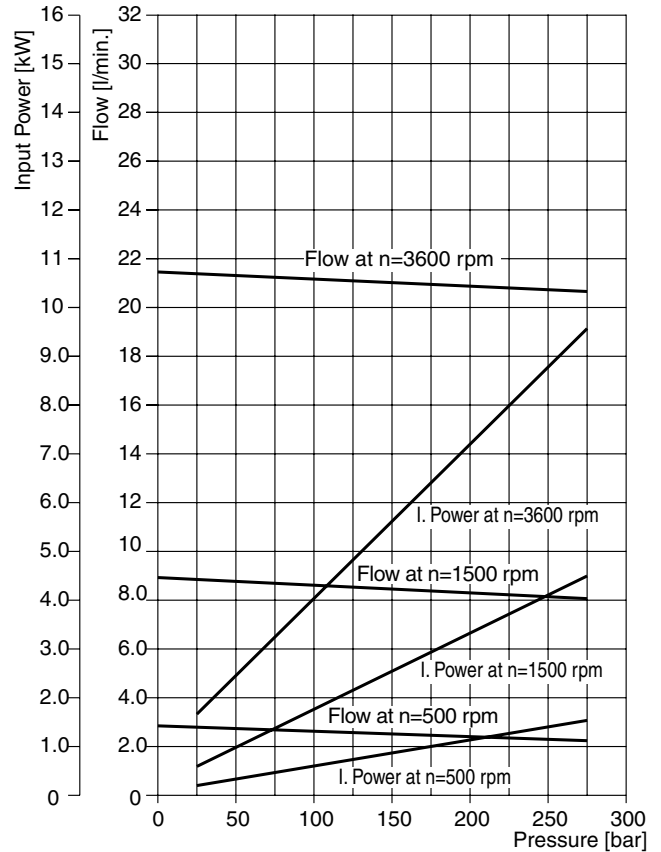

PGP505 - 10.0 CC

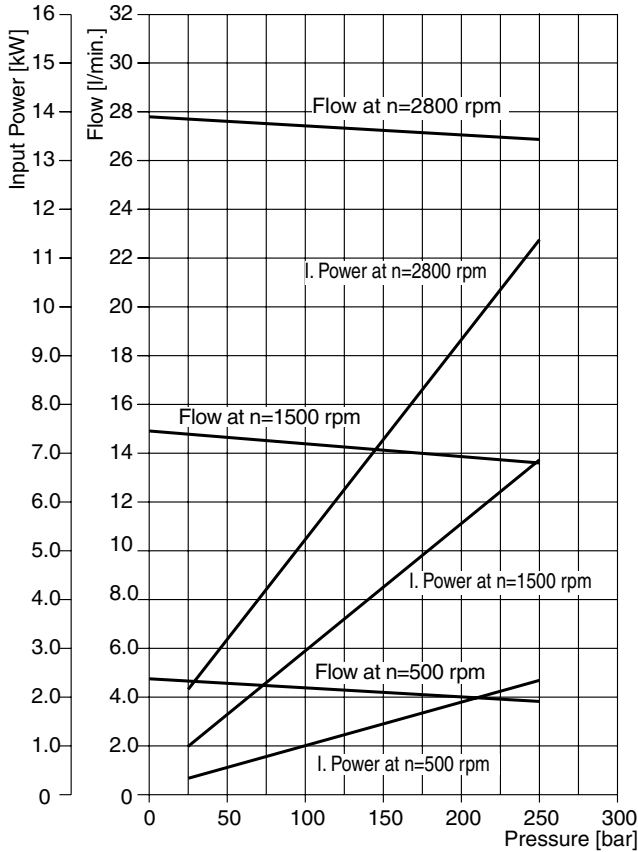

PGP505 - 12.0 CC

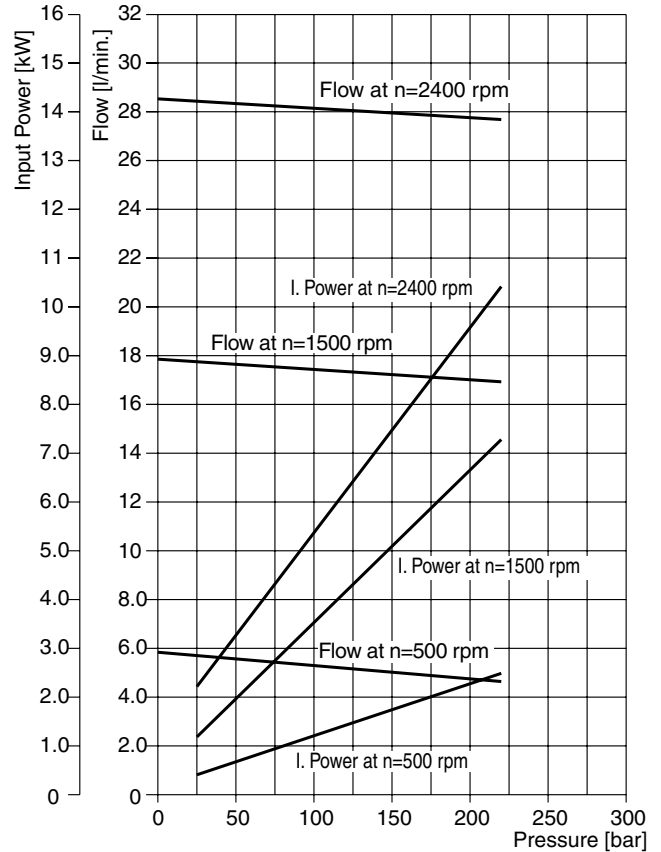

PI PGP-PGM UK.PMD RH Fluid temperature: 45 °C ± 2K ; Viscosity: 36mm²/s ; Inlet pressure: 0.9 + 0.1 bar absolute



PGP505 A XXXX Y A1 H2 N SS PP B1 B1

“Y” = C (clockwise rotation)
 = A (counter-clockwise rotation)

Displacement XXXX	cm ³ /rev	Dimension			Inlet port			Outlet port			Speed of rotation		Working pressure max. bar	Order number direction of rotation	
		A	B	C	SS	G	F	PP	G	F	min. rpm	max. rpm		clockwise	counter-clockwise
0030	3.0	35.9	41.1	79.8	E5	3/4"-14 BSP	42.0	E3	1/2"-14 BSP	34.0	500	4000	275	331 9111 385	
0040	4.0	37.2	43.8	79.8	E5	3/4"-14 BSP	42.0	E3	1/2"-14 BSP	34.0	500	4000	275	331 9111 386	
0060	6.0	39.8	49.1	84.8	E5	3/4"-14 BSP	42.0	E3	1/2"-14 BSP	34.0	500	3600	275	331 9111 387	
0080	8.0	42.5	54.5	89.8	E5	3/4"-14 BSP	42.0	E3	1/2"-14 BSP	34.0	500	3000	275	331 9111 383	331 9112 136
0100	10.0	45.2	59.8	100.8	E5	3/4"-14 BSP	42.0	E3	1/2"-14 BSP	34.0	500	2800	250	331 9111 388	
0120	12.0	47.9	65.2	104.8	E5	3/4"-14 BSP	42.0	E3	1/2"-14 BSP	34.0	500	2400	220	331 9111 389	

Dimensions (clockwise rotation shown)

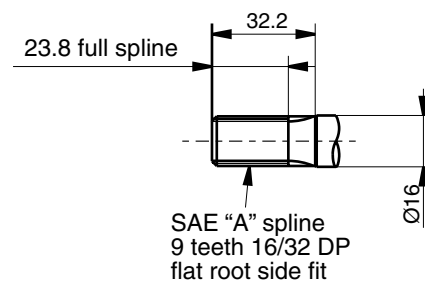
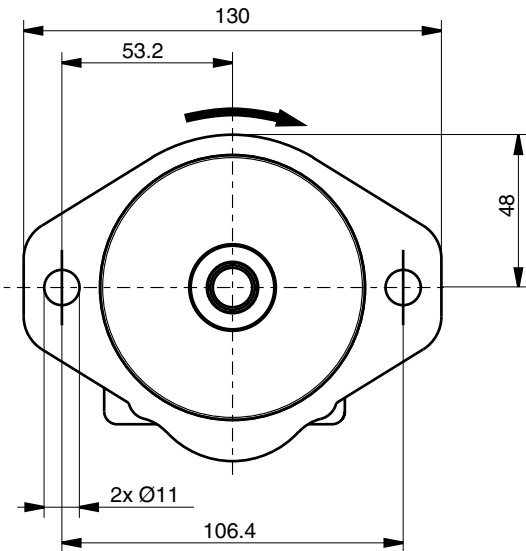
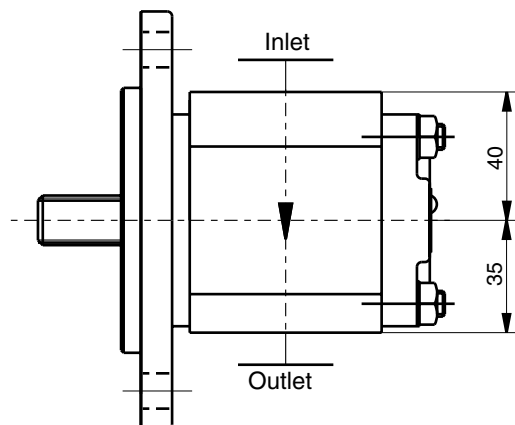
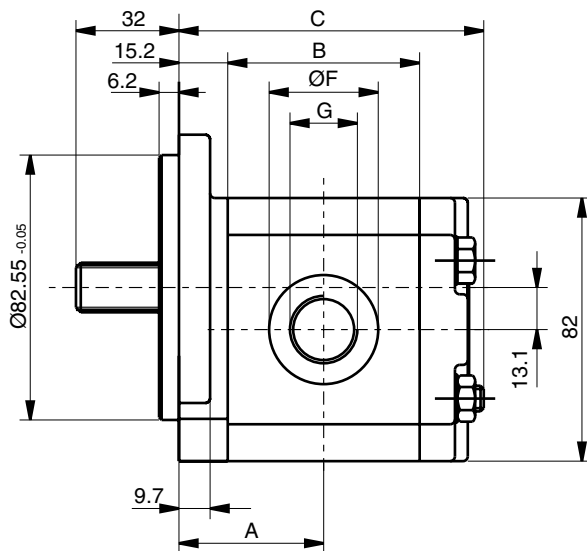
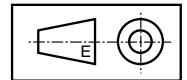

PGP505 A XXXX Y Q2 D2 N SS PP B1 B1

“Y” = C (clockwise rotation)
 = A (counter-clockwise rotation)

Displacement		Dimension			Inlet port			Outlet port			Speed of rotation		Working pressure	Order number direction of rotation			
XXXX	cm ³ /rev	A	B	C	SS	d	D	G	PP	d	D	G	min. rpm	max. rpm	max. bar	clockwise	counter-clockwise
0030	3.0	35.9	41.1	74.3	J7	20.0	40.0	M6	J5	15.0	35.0	M6	500	4000	275	331 9111 334	
0040	4.0	37.2	43.8	76.4	J7	20.0	40.0	M6	J5	15.0	35.0	M6	500	4000	275	331 9111 039	331 9112 061
0060	6.0	39.8	49.1	81.7	J7	20.0	40.0	M6	J5	15.0	35.0	M6	500	3600	275	331 9111 040	331 9112 077
0080	8.0	42.5	54.5	87.1	J7	20.0	40.0	M6	J5	15.0	35.0	M6	500	3000	275	331 9111 041	331 9112 078
0100	10.0	45.2	59.8	92.4	J7	20.0	40.0	M6	J5	15.0	35.0	M6	500	2800	250	331 9111 087	331 9112 033
0120	12.0	47.9	65.2	97.8	J7	20.0	40.0	M6	J5	15.0	35.0	M6	500	2400	220	331 9111 246	331 9112 135

Dimensions (clockwise rotation shown)

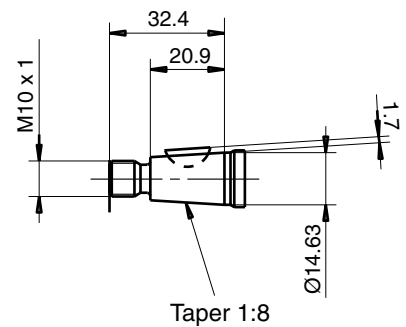
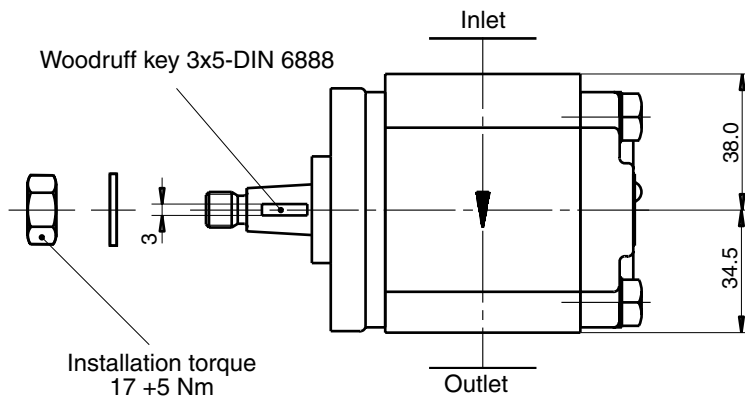
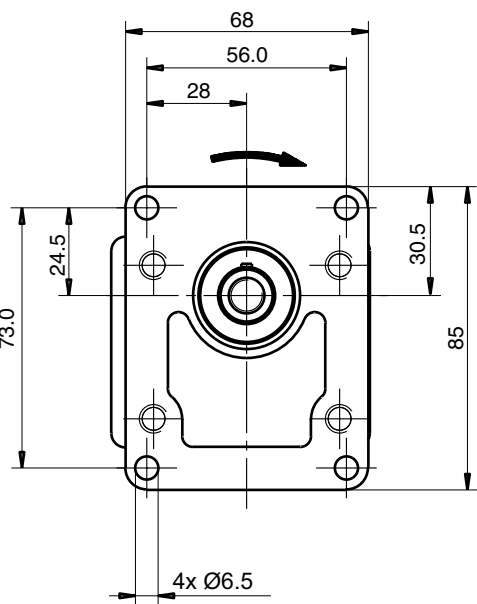
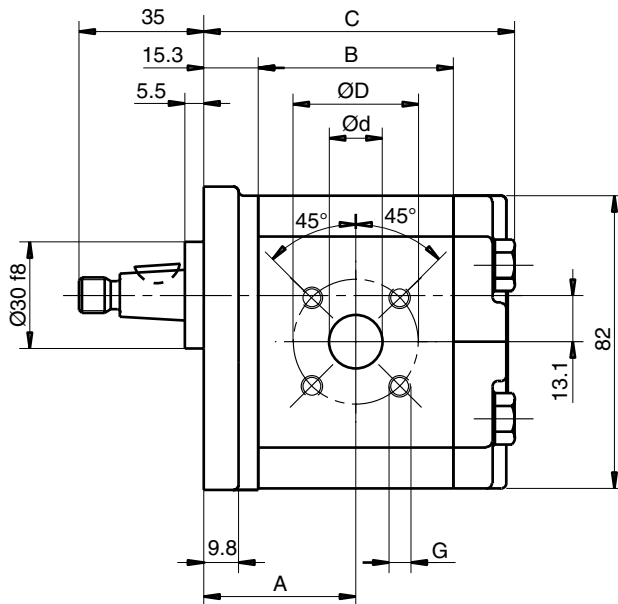
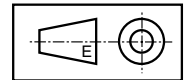

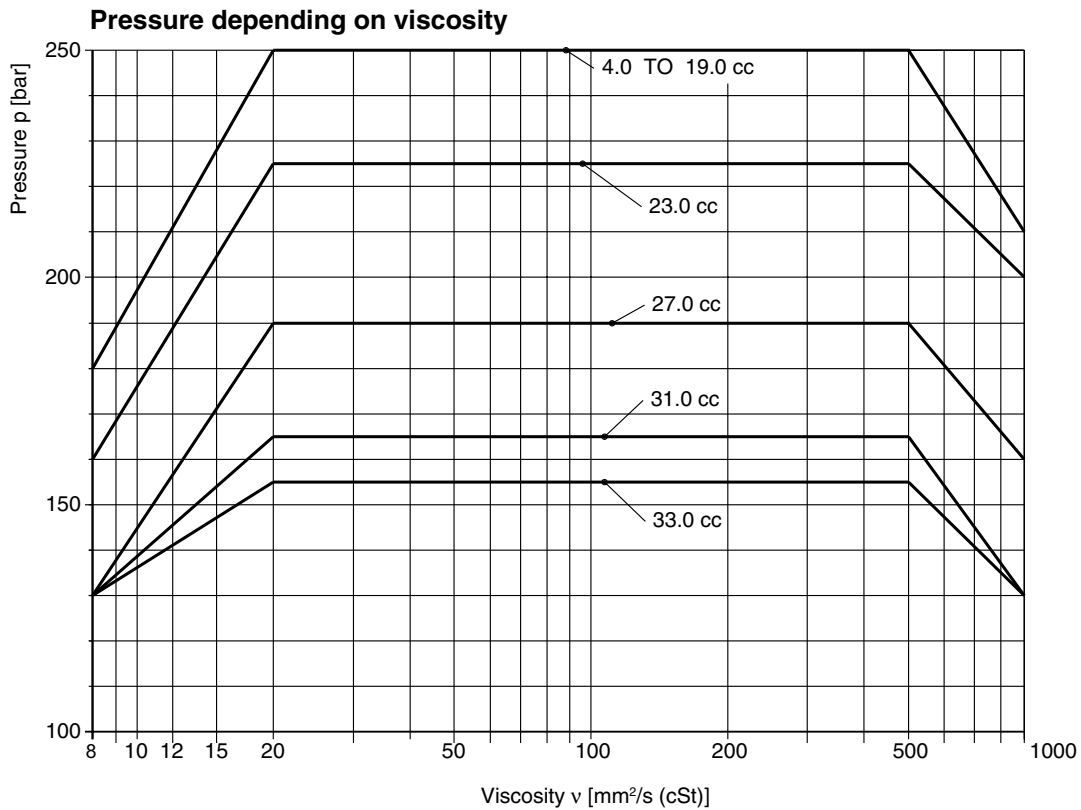
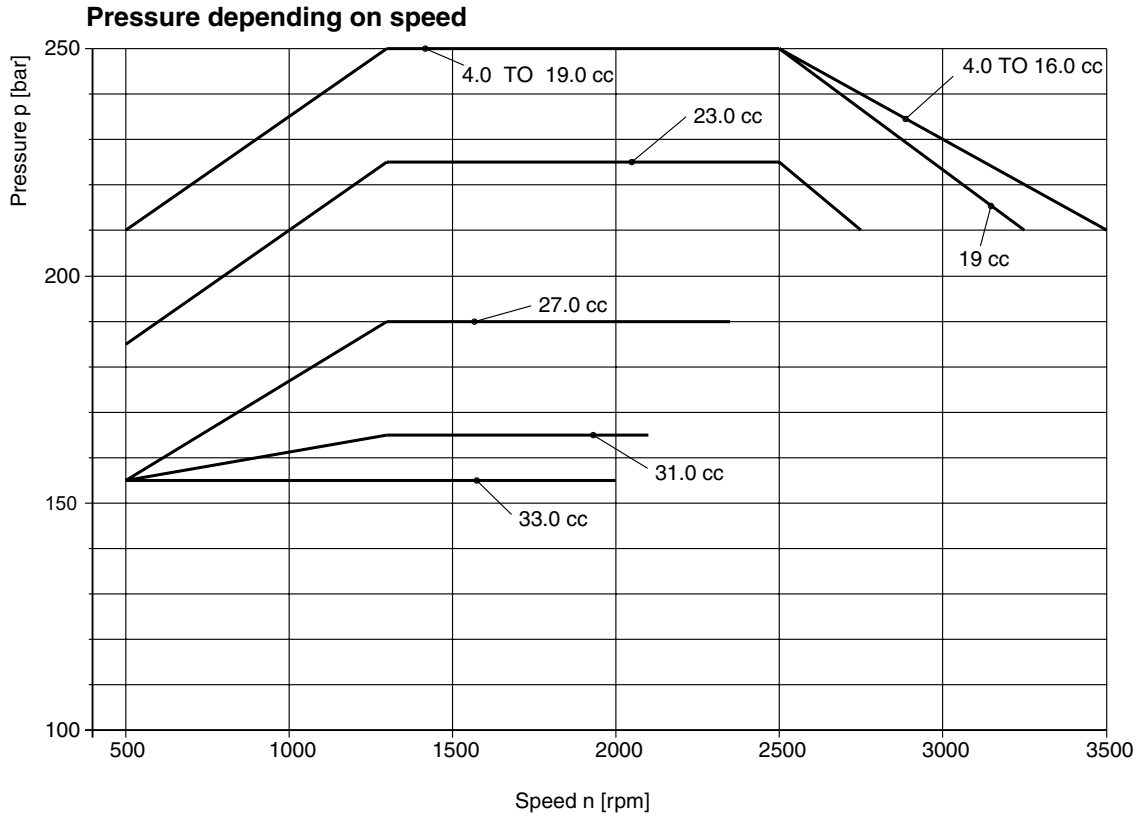

PGP511 - 6.0 CC

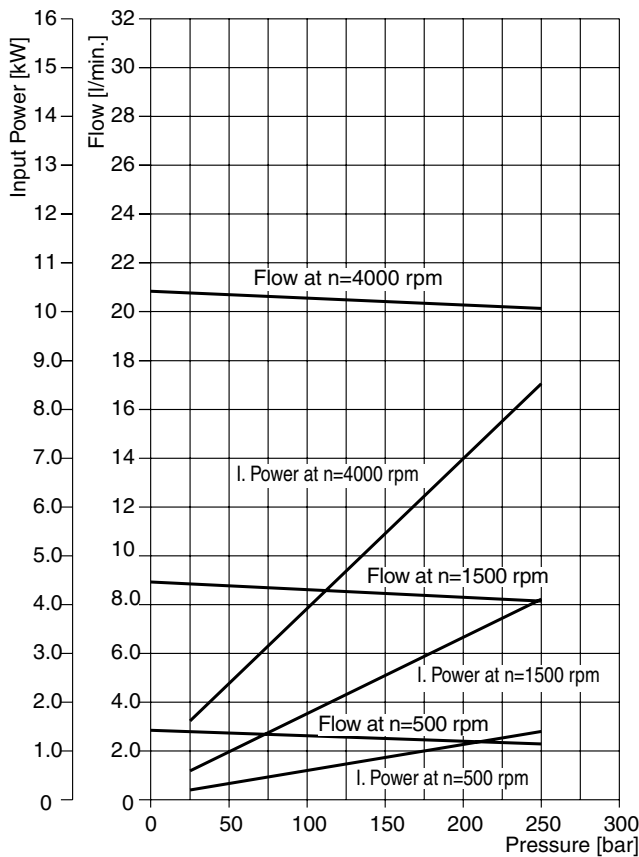

PGP511 - 10.0 CC

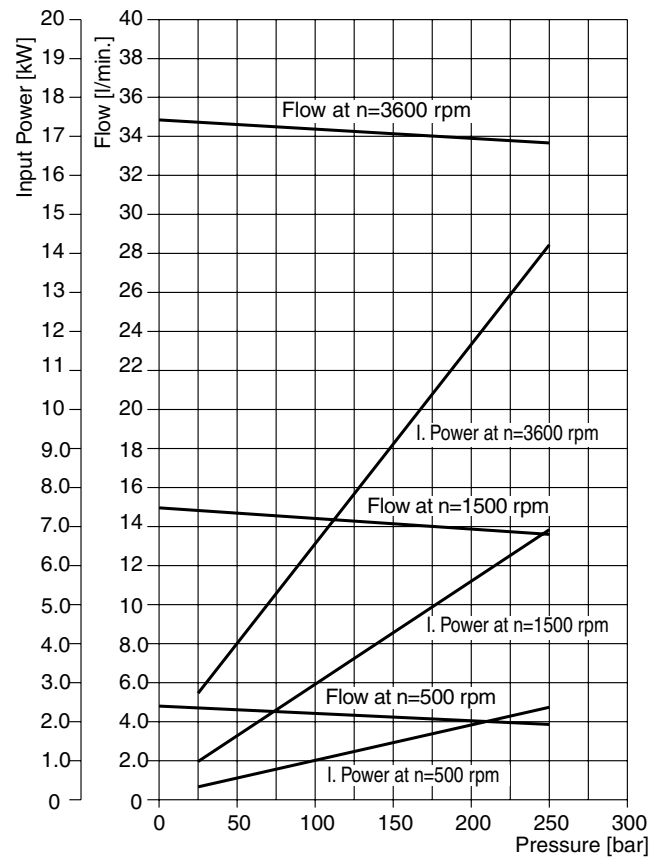

PGP511 - 19.0 CC

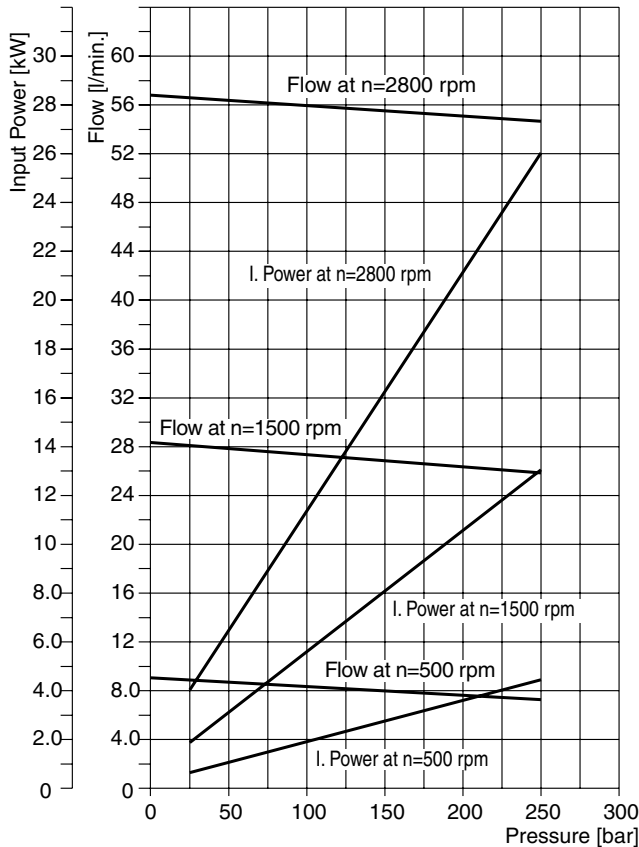

PGP511 - 33.0 CC

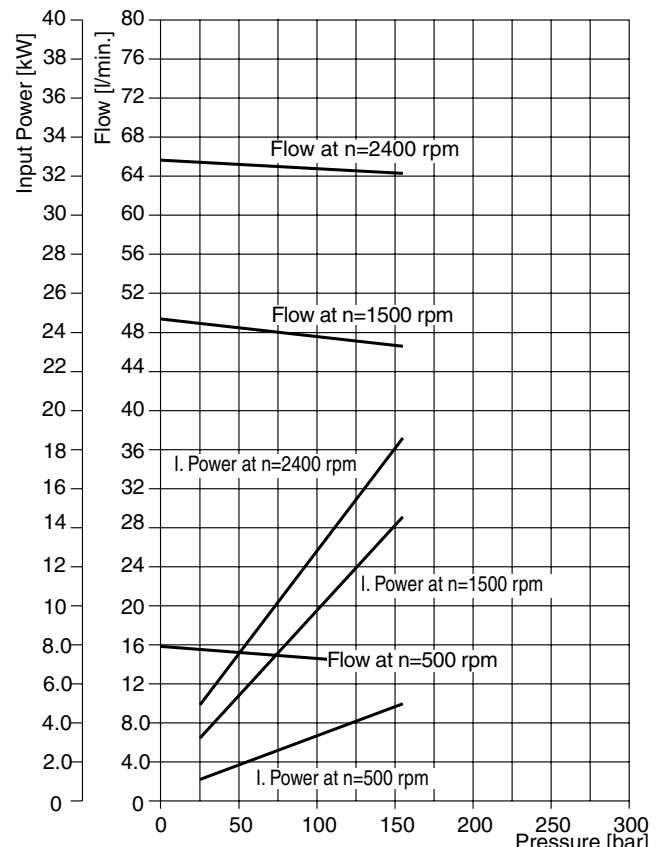

PI PGP-PGM UK.PMD RH

Fluid temperature: 45 °C ± 2K ; Viscosity: 36mm²/s ;

Inlet pressure: 0.9 + 0.1 bar absolute



PGP511 A XXXX Y A1 H2 N SS PP B1 B1

“Y” = C (clockwise rotation)
 = A (counter-clockwise rotation)

Displacement		Dimension			Inlet port			Outlet port			Speed of rotation		Working pressure max. bar	Order number direction of rotation	
XXXX	cm ³ /rev	A	B	C	SS	G	F	PP	G	F	min. rpm	max. rpm		clockwise	counter-clockwise
0040	4.0	42.6	47.0	86.7	E5	3/4"-14 BSP	42.0	E3	1/2"-14 BSP	34.0	500	3500	250		
0060	6.0	44.1	50.1	89.8	E5	3/4"-14 BSP	42.0	E3	1/2"-14 BSP	34.0	500	3500	250	334 9111 044	334 9112 621
0080	8.0	45.7	53.3	93.0	E5	3/4"-14 BSP	42.0	E3	1/2"-14 BSP	34.0	500	3500	250	334 9111 562	334 9112 622
0100	10.0	47.3	56.5	96.1	E5	3/4"-14 BSP	42.0	E3	1/2"-14 BSP	34.0	500	3500	250	334 9111 130	334 9112 628
0110	11.0	48.1	58.0	97.7	E5	3/4"-14 BSP	42.0	E3	1/2"-14 BSP	34.0	500	3500	250	334 9111 039	334 9112 023
0140	14.0	50.4	62.8	102.4	E5	3/4"-14 BSP	42.0	E3	1/2"-14 BSP	34.0	500	2700	250	334 9111 563	334 9112 623
0160	16.0	52.0	65.9	105.6	E6	1"-11 BSP	50.0	E5	3/4"-14 BSP	42.0	500	3500	250	334 9111 092	334 9112 060
0190	19.0	54.4	70.6	110.3	E6	1"-11 BSP	50.0	E5	3/4"-14 BSP	42.0	500	3200	250	334 9111 193	334 9112 624
0230	23.0	57.5	76.9	116.6	E6	1"-11 BSP	50.0	E5	3/4"-14 BSP	42.0	500	2700	210	334 9111 564	
0270	27.0	60.7	83.2	122.9	E6	1"-11 BSP	50.0	E5	3/4"-14 BSP	42.0	500	2300	180	334 9111 942	334 9112 494
0310	31.0	63.8	89.5	129.2	E6	1"-11 BSP	50.0	E5	3/4"-14 BSP	42.0	500	2000	160	334 9111 207	334 9112 229
0330	33.0	65.4	92.6	132.3	E6	1"-11 BSP	50.0	E5	3/4"-14 BSP	42.0	500	1800	150		334 9112 773

Dimensions (clockwise rotation shown)

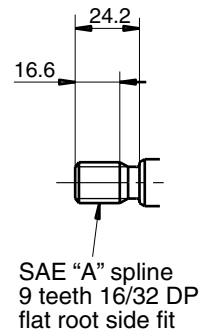
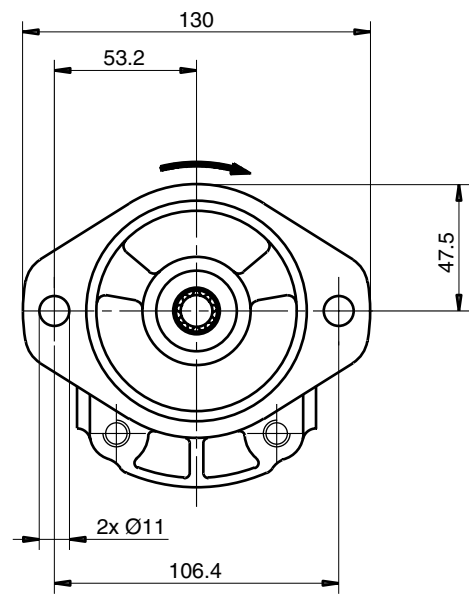
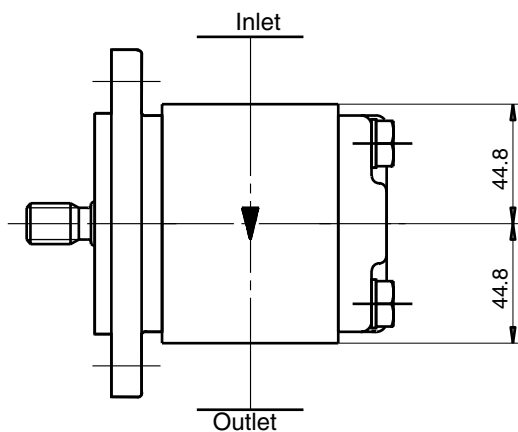
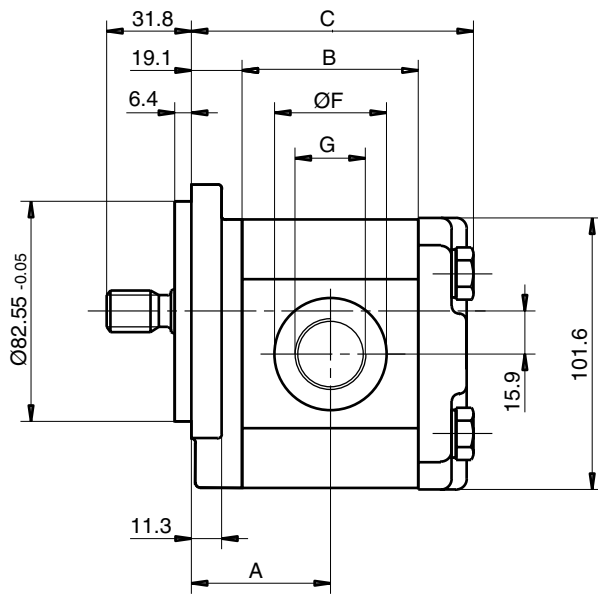
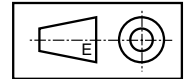

PGP511 A XXXX Y S1 D4 N SS PP B1 B1

“Y” = C (clockwise rotation)
 = A (counter-clockwise rotation)

Displacement XXXX	cm ³ /rev	Dimension			Inlet port				Outlet port				Speed of rotation		Working pressure max. bar	Order number direction of rotation	
		A	B	C	SS	d	D	G	PP	d	D	G	min. rpm	max. rpm		clockwise	counter-clockwise
0040	4.0	42.6	47.0	86.7	J7	20	40	M6	J5	15	35	M6	500	3500	250	334 9111 149	334 9112 289
0060	6.0	44.1	50.1	89.8	J7	20	40	M6	J5	15	35	M6	500	3500	250	334 9111 465	334 9112 298
0080	8.0	45.7	53.3	93.0	J7	20	40	M6	J5	15	35	M6	500	3500	250	334 9111 151	334 9112 291
0100	10.0	47.4	56.5	96.1	J7	20	40	M6	J5	15	35	M6	500	3500	250	334 9111 466	334 9112 292
0110	11.0	48.1	58.0	97.7	J7	20	40	M6	J5	15	35	M6	500	3500	250	334 9111 152	334 9112 238
0140	14.0	50.4	62.8	102.4	J7	20	40	M6	J5	15	35	M6	500	3400	250	334 9111 153	334 9112 239
0160	16.0	52.0	65.9	105.6	J7	20	40	M6	J5	15	35	M6	500	3000	250	334 9111 154	334 9112 120
0190	19.0	54.4	70.6	110.3	J9	26	55	M8	J8	18	55	M8	500	3250	250	334 9111 970	
0230	23.0	57.5	76.9	116.6	J9	26	55	M8	J8	18	55	M8	500	2750	225	334 9111 971	
0270	27.0	60.7	83.2	122.9	J9	26	55	M8	J8	18	55	M8	500	2350	190	334 9111 972	334 9112 807
0310	31.0	63.8	89.5	129.2	J9	26	55	M8	J8	18	55	M8	500	2100	165	334 9111 526	
0330	33.0	65.4	92.6	132.3	J9	26	55	M8	J8	18	55	M8	500	2000	155	334 9111 973	

Dimensions (clockwise rotation shown)

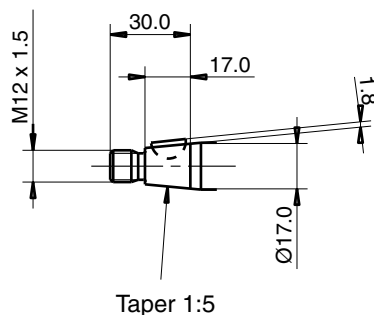
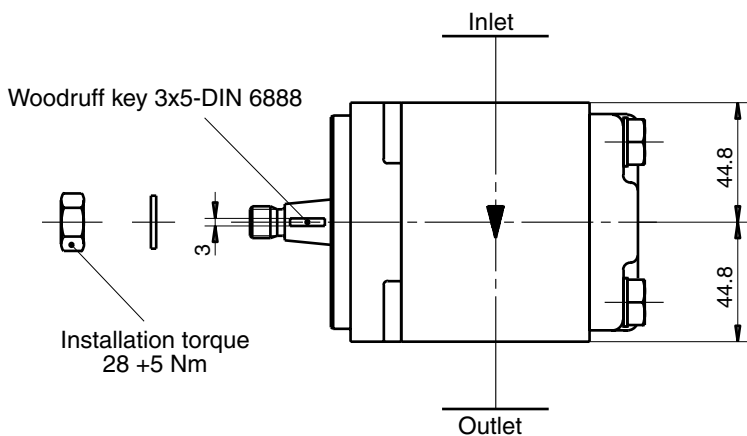
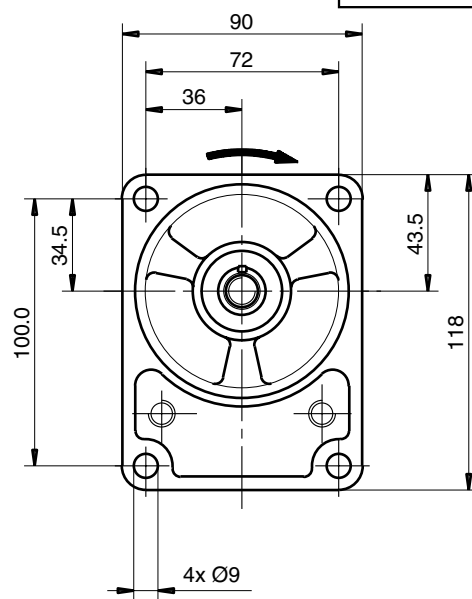
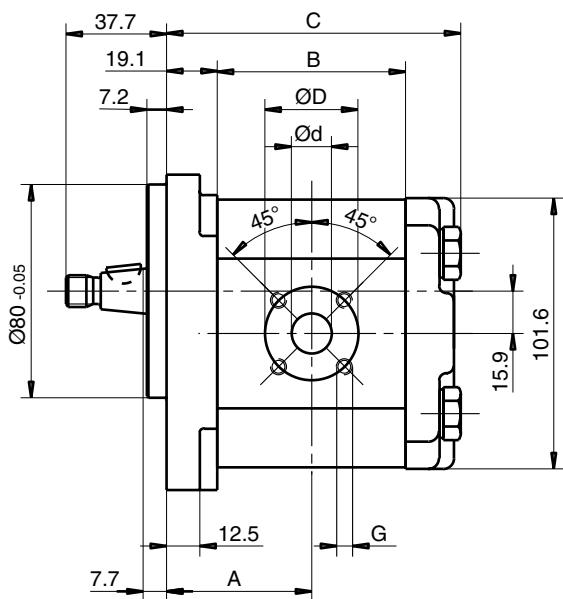
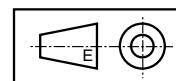

PGP511 A XXXX Y S2 D3 N SS PP B1 B1

“Y” = C (clockwise rotation)
 = A (counter clockwise rotation)

Displacement		Dimension			Inlet port			Outlet port			Speed of rotation		Working pressure	Order number direction of rotation			
XXXX	cm ³ /rev	A	B	C	SS	d	D	G	PP	d	D	G	min. rpm	max. rpm	max. bar	clockwise	counter-clockwise
0040	4.0	42.6	47.0	86.7	L1	13	30	M6	L1	13	30	M6	500	3500	250	334 9111 403	334 9112 398
0060	6.0	44.1	50.1	89.8	L1	13	30	M6	L1	13	30	M6	500	3500	250	334 9111 404	334 9112 395
0080	8.0	45.7	53.3	93.0	L1	13	30	M6	L1	13	30	M6	500	2500	250	334 9111 091	334 9112 397
0100	10.0	47.3	56.5	96.1	L2	19	40	M8	L1	13	30	M6	500	3500	250	334 9111 975	334 9112 618
0110	11.0	48.1	58.0	97.7	L2	19	40	M8	L1	13	30	M6	500	3500	250	334 9111 976	334 9112 399
0140	14.0	50.4	62.8	102.4	L2	19	40	M8	L1	13	30	M6	500	3100	250	334 9111 292	334 9112 400
0160	16.0	52.0	65.9	105.6	L2	19	40	M8	L1	13	30	M6	500	2700	250	334 9111 293	334 9112 601
0190	19.0	54.4	70.6	110.3	L2	19	40	M8	L2	19	40	M8	500	2300	250	334 9111 977	
0230	23.0	57.5	76.9	116.6	L2	19	40	M8	L2	19	40	M8	500	1900	225	334 9111 295	
0270	27.0	60.7	83.2	122.9	L2	19	40	M8	L2	19	40	M8	500	1600	190	334 9111 296	
0310	31.0	63.8	89.5	129.2	L2	19	40	M8	L2	19	40	M8	500	1500	165	334 9111 978	
0330	33.0	65.4	92.6	132.3	L2	19	40	M8	L2	19	40	M8	500	1500	155	334 9111 297	

Dimensions (clockwise rotation shown)

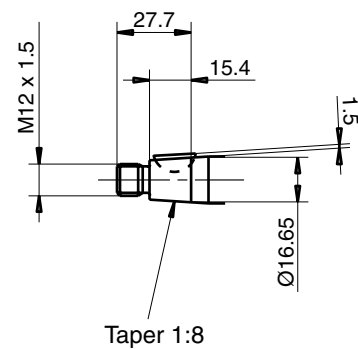
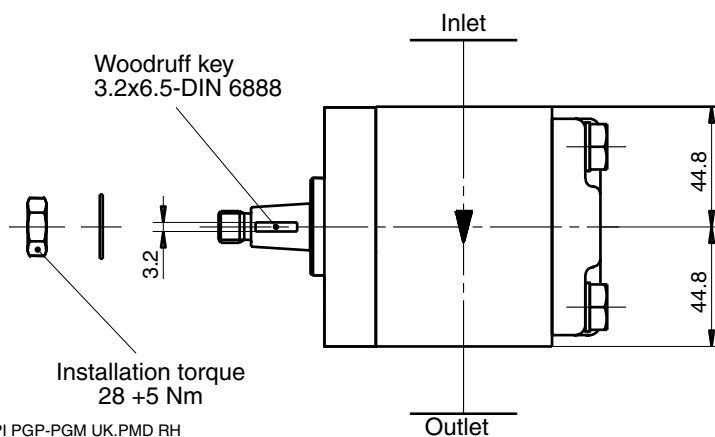
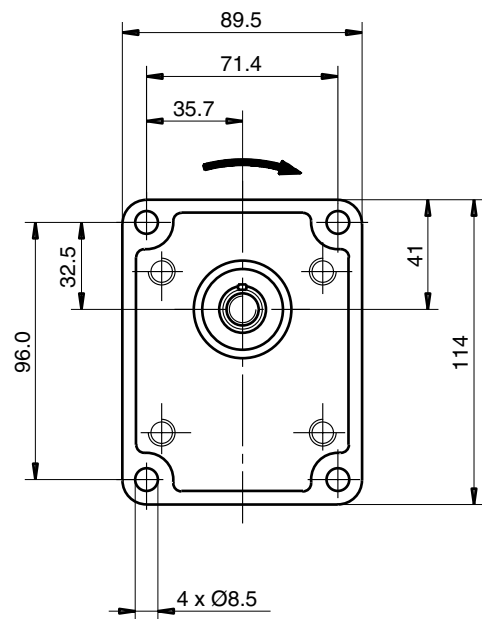
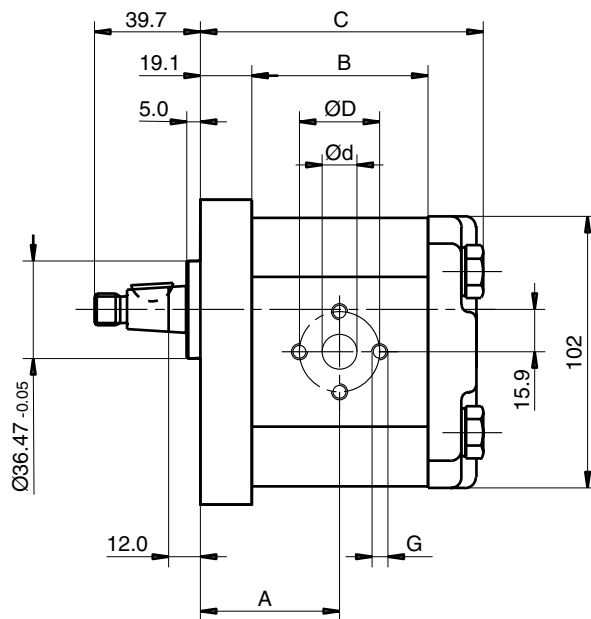
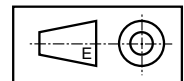

PI PGP-PGM UK.PMD RH



PGM511 A XXXX B S1 D4 N PP SS B1 B1 G4

“B” = B (bi-directional)

Displacement XXXX	cm³/rev	Dimension			Inlet port			Outlet port			Speed of rotation		Working pressure max. bar	Order number direction of rotation bi-directional		
		A	B	C	PP	d	D	G	SS	d	D	G			min. rpm	max. rpm
0060	6.0	44.1	50.1	89.8	J5	20	40	M6	J5	15	35	M6	500	3500	250	334 9219 253
0080	8.0	45.7	53.3	93.0	J5	20	40	M6	J5	15	35	M6	500	3500	250	
0100	10.0	47.3	56.5	96.1	J5	20	40	M6	J5	15	35	M6	500	3500	250	
0110	11.0	48.1	58.0	97.7	J5	20	40	M6	J5	15	35	M6	500	3500	250	
0140	14.0	50.4	62.8	102.4	J5	20	40	M6	J5	15	35	M6	500	3400	250	
0160	16.0	52.0	65.9	105.6	J5	20	40	M6	J5	15	35	M6	500	3000	250	
0190	19.0	54.4	70.6	110.3	J5	20	40	M6	J5	15	35	M6	500	3250	250	334 9219 356
0230	23.0	57.5	76.9	116.6	J5	20	40	M6	J5	15	35	M6	500	2750	225	
0270	27.0	60.7	83.2	122.9	J5	20	40	M6	J5	15	35	M6	500	2350	190	334 9219 200
0310	31.0	63.8	89.5	129.2	J5	20	40	M6	J5	15	35	M6	500	2100	165	
0330	33.0	65.4	92.6	132.3	J5	20	40	M6	J5	15	35	M6	500	2000	155	

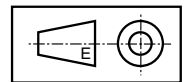

Dimensions (bi-directional motor shown)

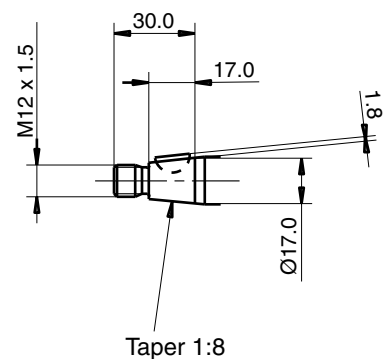
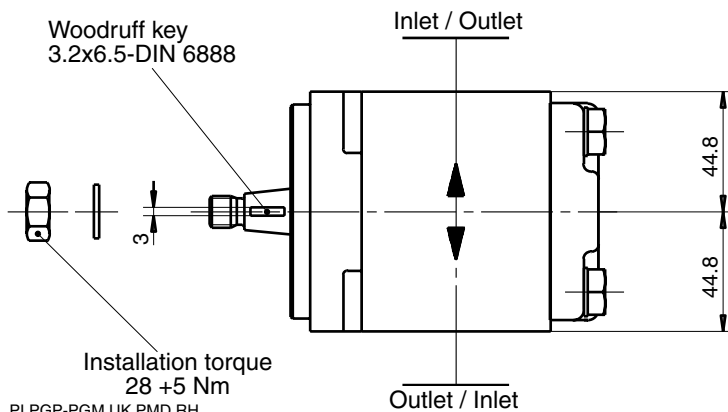
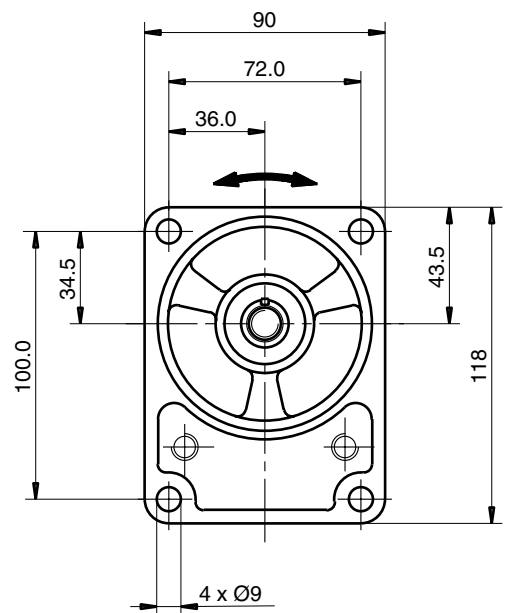
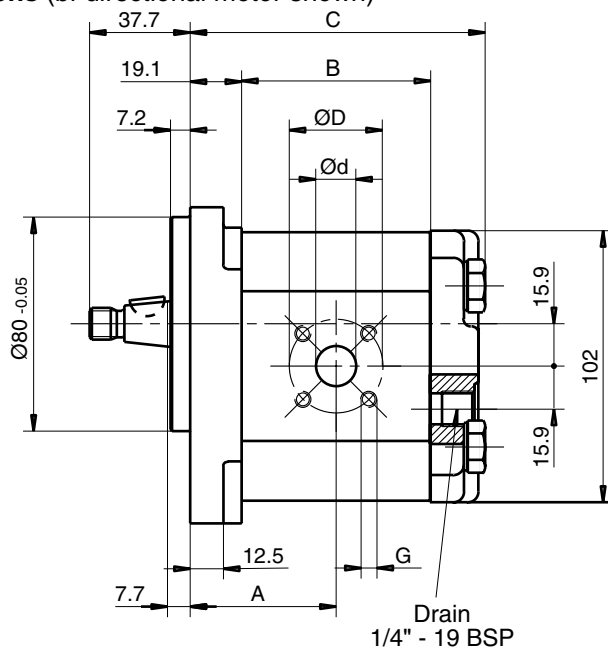

PI PGP-PGM UK.PMD RH



PG **517** **B 1 B 1**

Gear design

Type

Unit

**Dis-
placement**

Rotation

Shaft

Flange

Shaft seal

Inlet side ports option

Outlet side ports option

No rear ports
(rear ports on request)

Code	Type
P	Pump

Code	Unit
	Pump
A	Single unit
M	Single distributor unit
B	Multiple unit

Displacement	
Code	ccm
0140	14.0
0160	16.0
0190	19.0
0230	23.0
0250	25.0
0280	28.0
0330	33.0
0380	38.0
0440	44.0
0520	52.0
0700	70.0

Code	Rotation
C	Clockwise
A	Counter-clockwise

Code	Shaft
D1 ²⁾	13T, 16/32DP, 41.2L, SAE "B" spline
M1 ²⁾	Ø22.2, 6.3key, no thread, 41.2L, SAE "B", parallel
M2 ²⁾	Ø25.4, 6.3key, no thread, 46L, SAE "B-B", parallel
T1 ³⁾	Ø21.59, 11.2L, 4.0key, M14x1.5, taper 1:8

Code	Port options
E6E5	1"-11 BSP thread/ 3/4"-14 BSP thread rec. from 14 ccm to 19 ccm
E7E6	1 1/4"-11 BSP thread/ 1"-11 BSP thread rec. from 23 ccm to 38 ccm
E8E6	1 1/2"-11 BSP thread/ 1"-11 BSP thread rec. from 44 ccm to 70 ccm
J9J8	Ø26 mm-Ø55 mm-M8 square flange Ø18 mm-Ø55 mm-M8 square flange rec. from 14 ccm to 52 ccm
L3L2	Ø27 mm-Ø51 mm-M10 diamond flange Ø19 mm-Ø40 mm-M8 diamond flange rec. from 14 ccm to 52 ccm
P3P2	1"-M10 SAE metric flange 3/4"-M10 SAE metric flange rec. from 16 ccm to 23 ccm
P4P3	1 1/4"-M10 SAE metric flange 1"-M10 SAE metric flange rec. from 25 ccm to 44 ccm
P5P3	1 1/2"-M12 SAE metric flange 1"-M10 SAE metric flange rec. from 44 ccm to 70 ccm

Example: P4 = inlet port
P3 = outlet port

Code	Shaft seal
X	No seal
N	NBR
V	FPM

Code	Flange
D7	98.4x128.2 - Ø50.77 rectangular
H3	146.1 - Ø101.06 SAE "B" 2 bolt flange

²⁾ Only used with flange H3.

³⁾ Only used with flange D7.

Pressure depending on speed

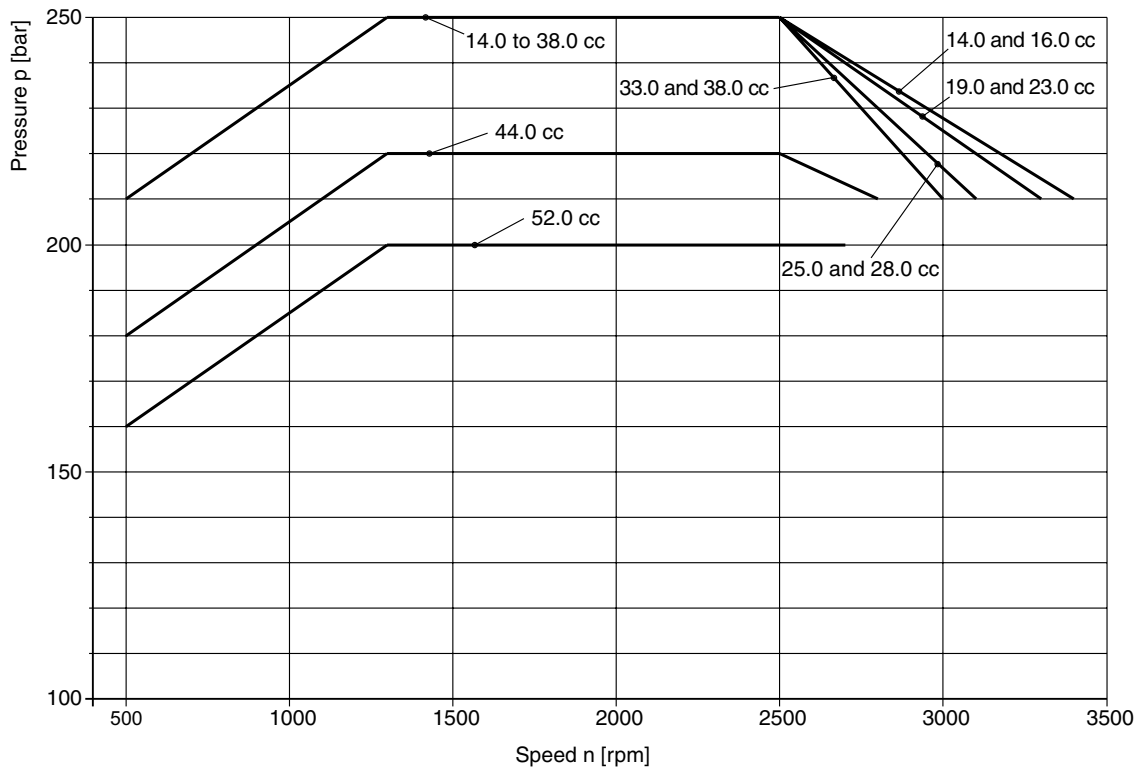

Pressure depending on viscosity

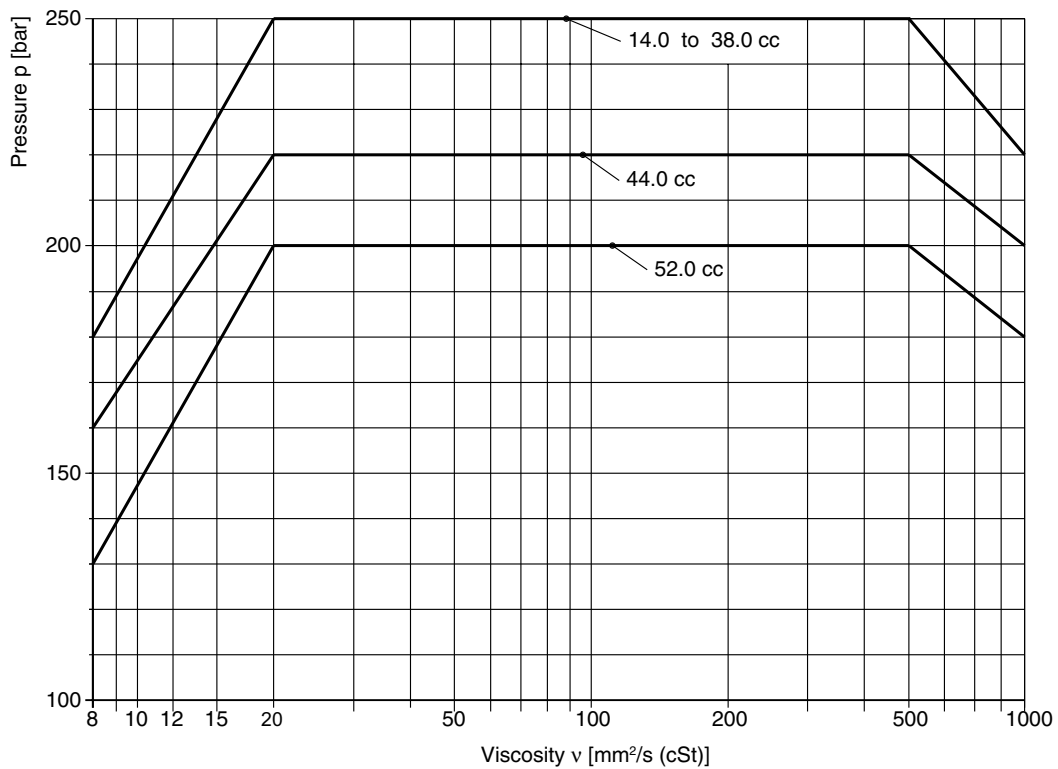

PGP517 - 14.0 CC

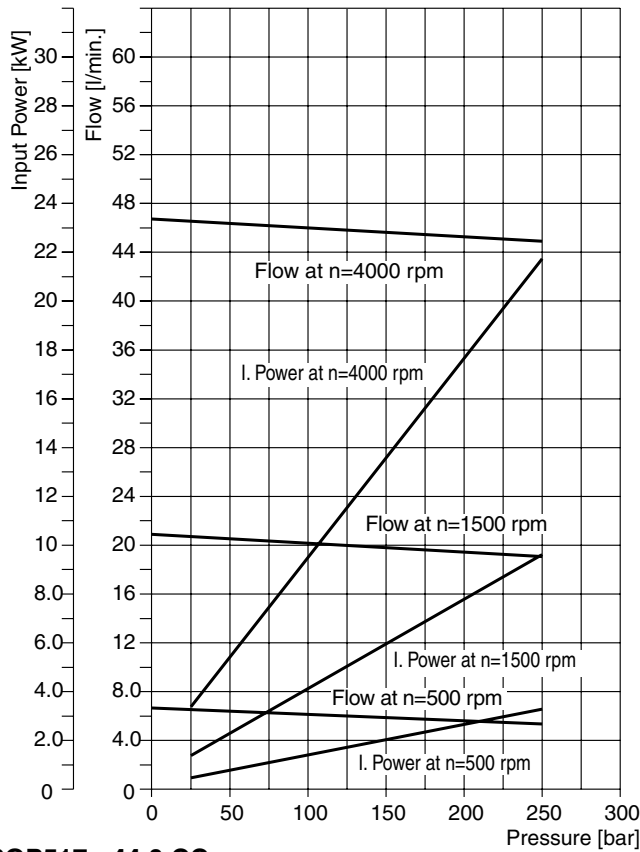

PGP517 - 25.0 CC

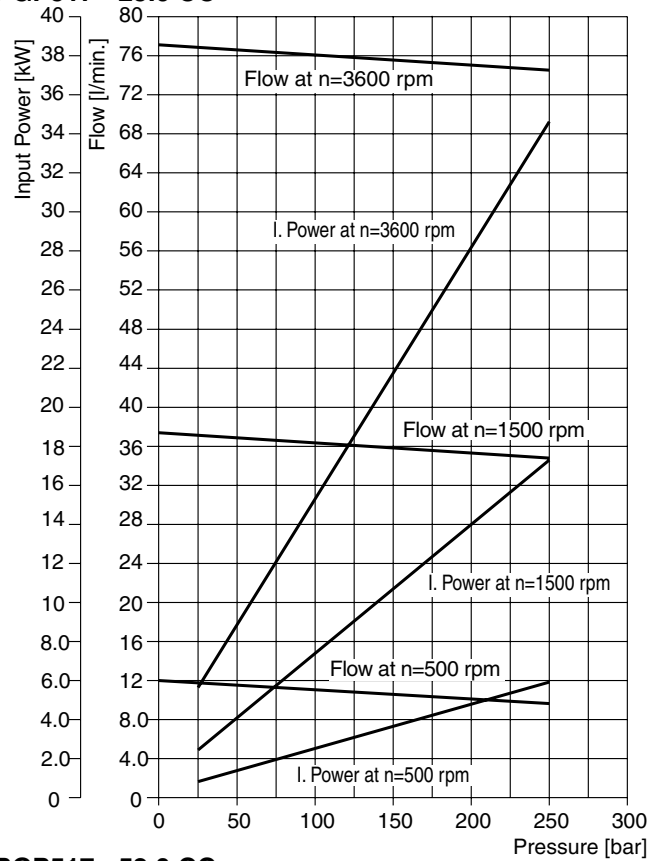

PGP517 - 44.0 CC

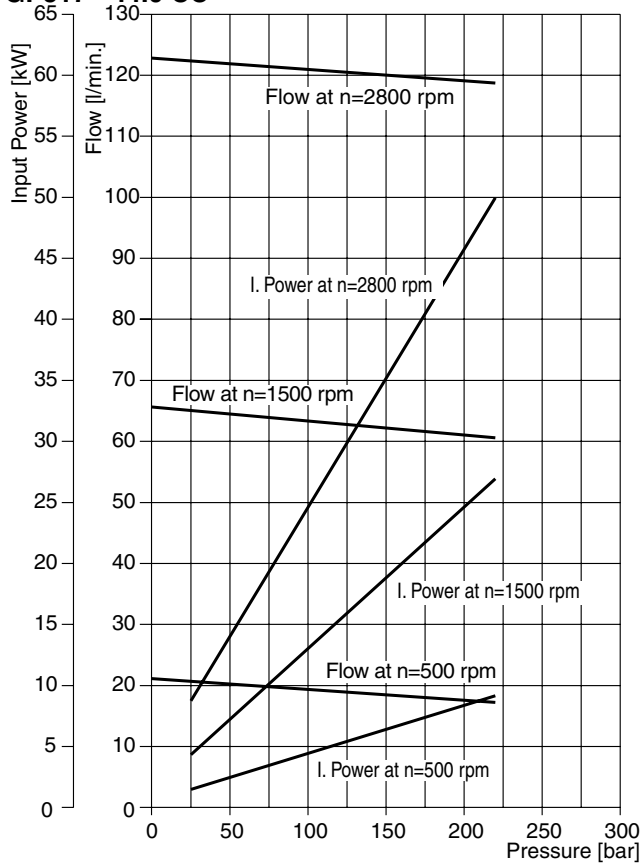

PGP517 - 52.0 CC

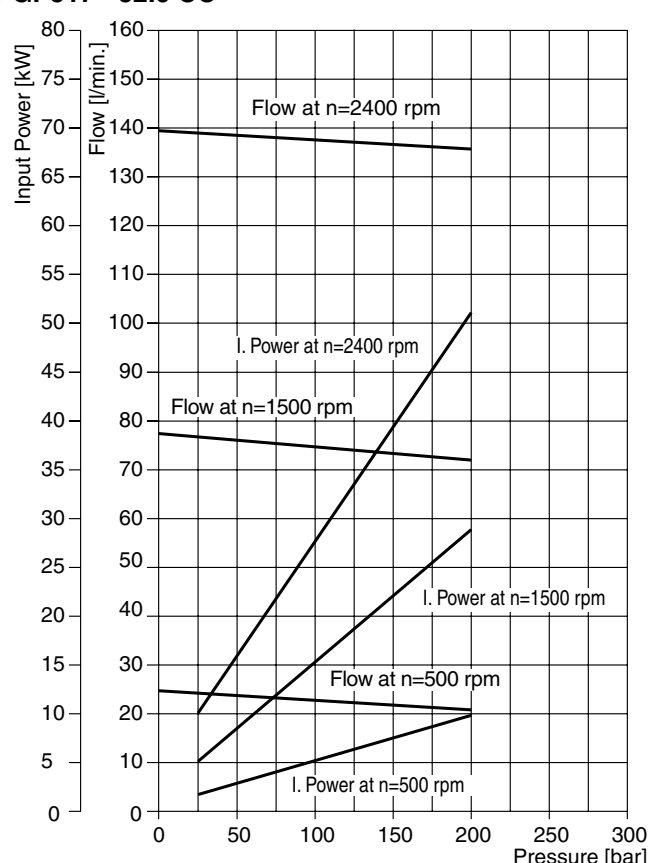

PI PGP-PGM UK.PMD RH

Fluid temperature: 45 °C ± 2K ; Viscosity: 36mm²/s ;

Inlet pressure: 0.9 + 0.1 bar absolute



PGP517 A XXXX Y D1 H3 N SS PP B1 B1

“Y” = C (clockwise rotation)
 = A (counter-clockwise rotation)

Displacement XXXX cm ³ / rev	Dimension			Inlet port					Outlet port					Speed of rotation		Working pressure max. bar	Order number direction of rotation	
	A	B	C	SS	d	G	H	W	PP	d	G	H	W	min. rpm	max. rpm		clockwise	counter-clockwise
0140	62.1	68.3	122.8	P2	3/4"	M10	47.63	22.23	P2	3/4"	M10	47.63	22.23	500	3000	250		
0160	63.2	70.3	124.8	P3	1"	M10	52.37	26.19	P2	3/4"	M10	47.63	22.23	500	3400	250		
0190	64.7	73.3	127.8	P3	1"	M10	52.37	26.19	P2	3/4"	M10	47.63	22.23	500	3300	250		333 9112 180
0230	66.7	77.4	131.9	P3	1"	M10	52.37	26.19	P2	3/4"	M10	47.63	22.23	500	3300	250	333 9111 193	333 9112 177
0250	67.7	79.4	133.9	P4	1 1/4"	M10	58.72	30.17	P3	1"	M10	52.37	26.19	500	3100	250		333 9112 388
0280	69.2	82.4	136.9	P4	1 1/4"	M10	58.72	30.17	P3	1"	M10	52.37	26.19	500	3100	250	333 9111 669	333 9112 274
0330	71.7	87.5	142.0	P4	1 1/4"	M10	58.72	30.17	P3	1"	M10	52.37	26.19	500	3000	250		333 9112 374
0380	74.3	92.5	147.0	P4	1 1/4"	M10	58.72	30.17	P3	1"	M10	52.37	26.19	500	3000	250	333 9111 290	333 9112 412
0440	77.3	98.6	153.1	P4	1 1/4"	M10	58.72	30.17	P3	1"	M10	52.37	26.19	500	2800	225	333 9111 150	333 9112 346
0520	81.3	106.7	161.2	P5	1 1/2"	M12	69.82	35.71	P3	1"	M10	52.37	26.19	500	2700	190	333 9111 360	333 9112 357
0700	90.4	124.9	179.4	P5	1 1/2"	M12	69.82	35.71	P3	1"	M10	52.37	26.19	500	2300	165	333 9111 563	

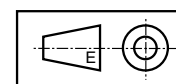

Dimensions (clockwise rotation shown)

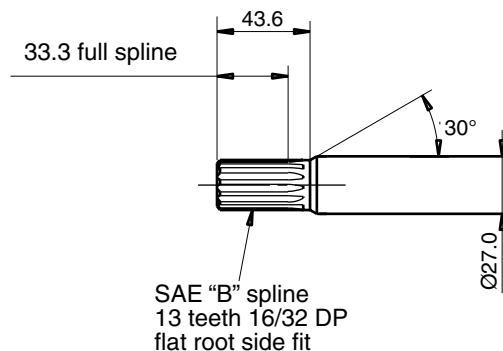
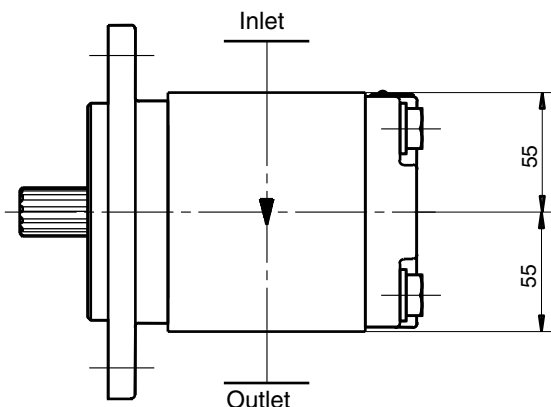
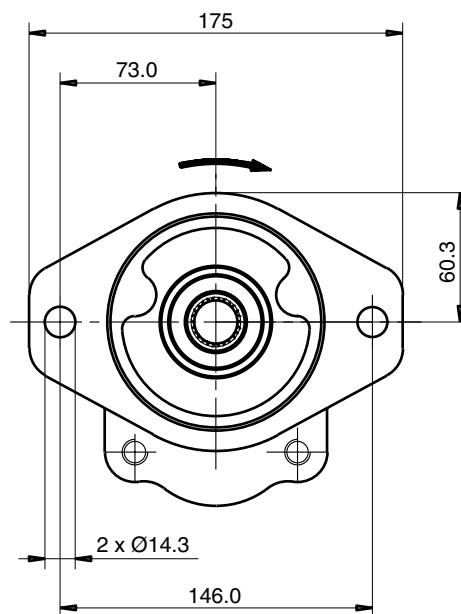
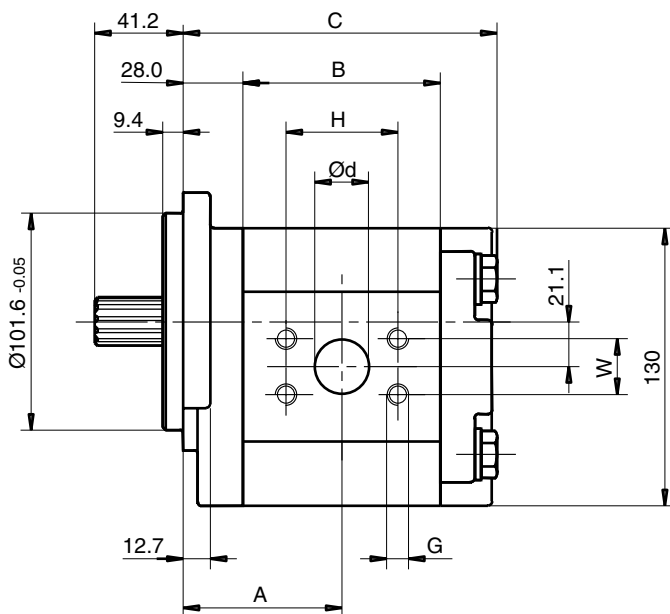

PI PGP-PGM UK.PMD RH



PGP517 A XXXX Y T1 D7 N SS PP B1 B1

“Y” = C (clockwise rotation)
 = A (counter-clockwise rotation)

Displacement XXXX	cm ³ /rev	Dimension			Inlet port			Outlet port			Speed of rotation		Working pressure max. bar	Order number direction of rotation			
		A	B	C	SS	d	D	G	PP	d	D	G		min. rpm	max. rpm	clockwise	counter-clockwise
0140	14.0	62.1	68.3	122.8	L3	27	51	M10	L2	19	40	M8	500	3400	250	333 9111 503	
0160	16.0	63.2	70.3	124.8	L3	27	51	M10	L2	19	40	M8	500	3400	250	333 9111 505	333 9112 430
0190	19.0	64.7	73.3	127.8	L3	27	51	M10	L2	19	40	M8	500	3300	250	333 9111 285	333 9112 212
0230	23.0	66.7	77.4	131.9	L3	27	51	M10	L2	19	40	M8	500	3300	250	333 9111 119	333 9112 213
0250	25.0	67.7	79.4	133.9	L3	27	51	M10	L2	19	40	M8	500	3100	250	333 9111 047	333 9112 068
0280	28.0	69.2	82.4	136.9	L3	27	51	M10	L2	19	40	M8	500	3100	250	333 9111 287	333 9112 214
0330	33.0	71.7	87.5	142.0	L3	27	51	M10	L2	19	40	M8	500	2600	250	333 9111 014	333 9112 035
0380	38.0	74.3	92.5	147.0	L3	27	51	M10	L2	19	40	M8	500	2300	250	333 9111 015	333 9112 036
0440	44.0	77.3	98.6	153.1	L3	27	51	M10	L2	19	40	M8	500	2000	220	333 9111 046	333 9112 040
0520	52.0	81.3	106.7	161.2	L3	27	51	M10	L2	19	40	M8	500	1700	200	333 9111 242	333 9112 215

Dimensions (clockwise rotation shown)

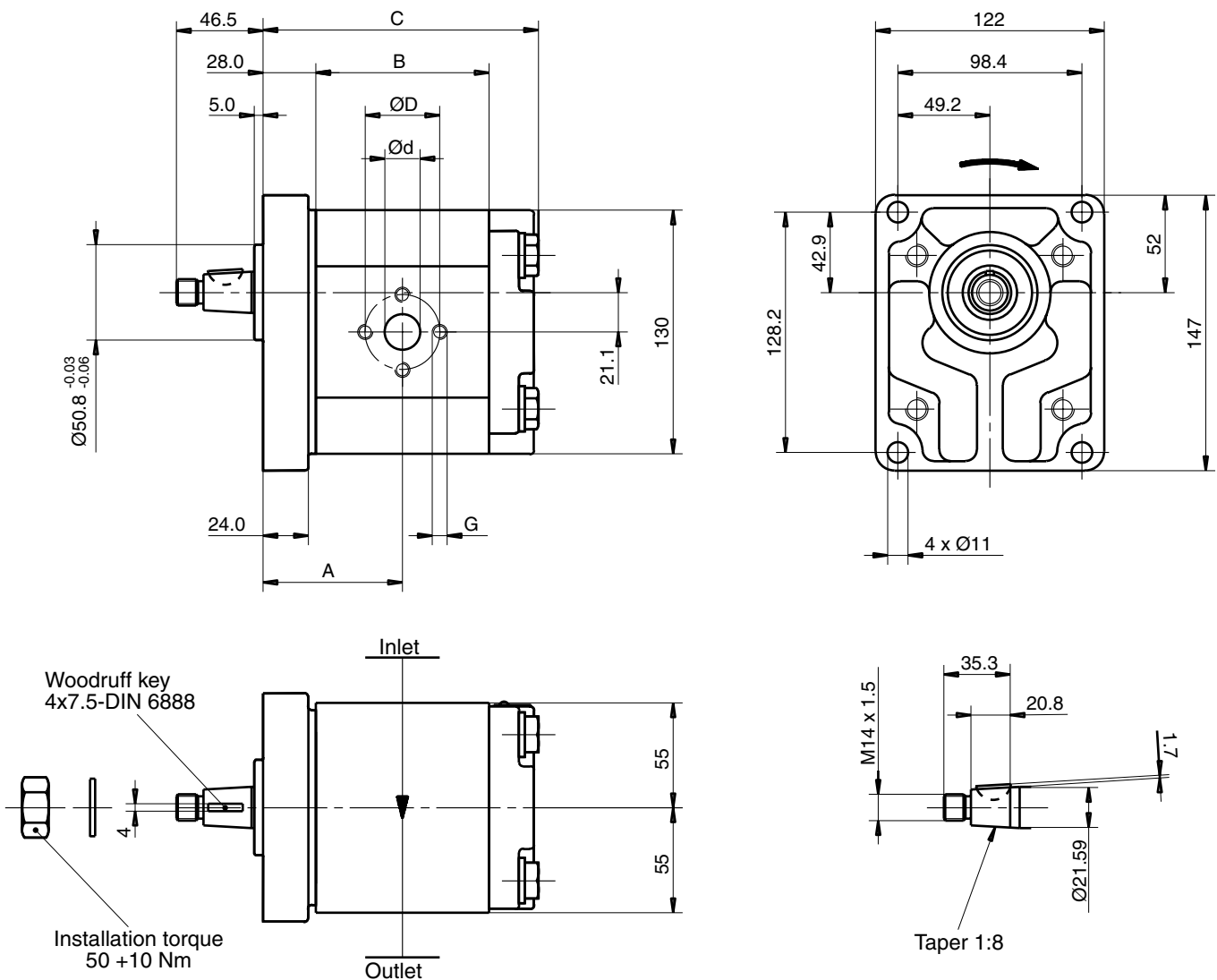
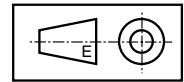

PI PGP-PGM UK.PMD RH



Code for multiple units

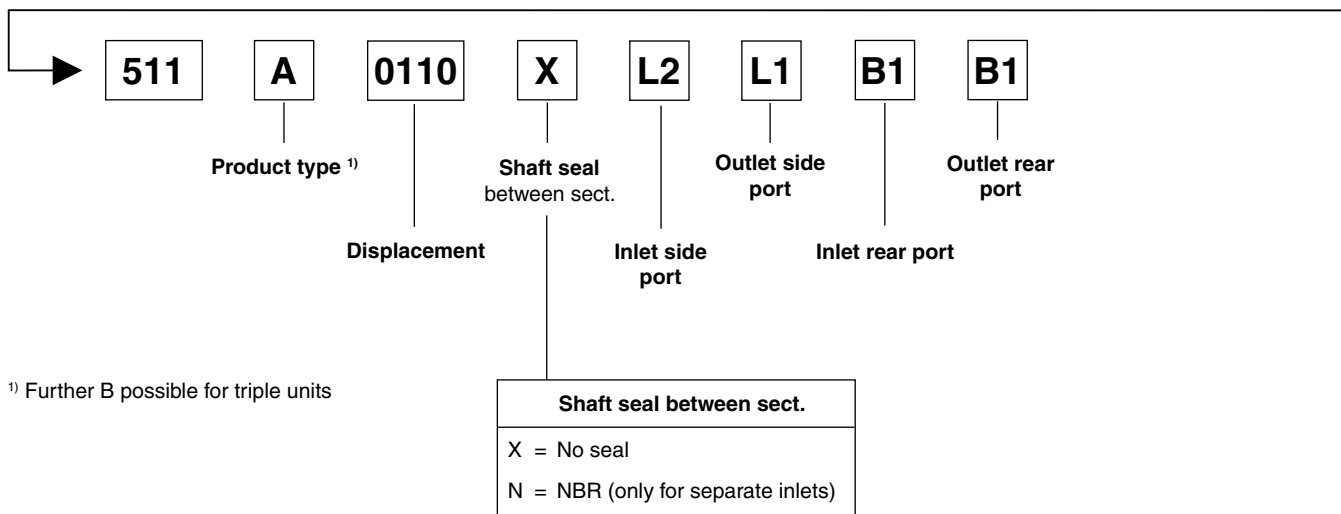
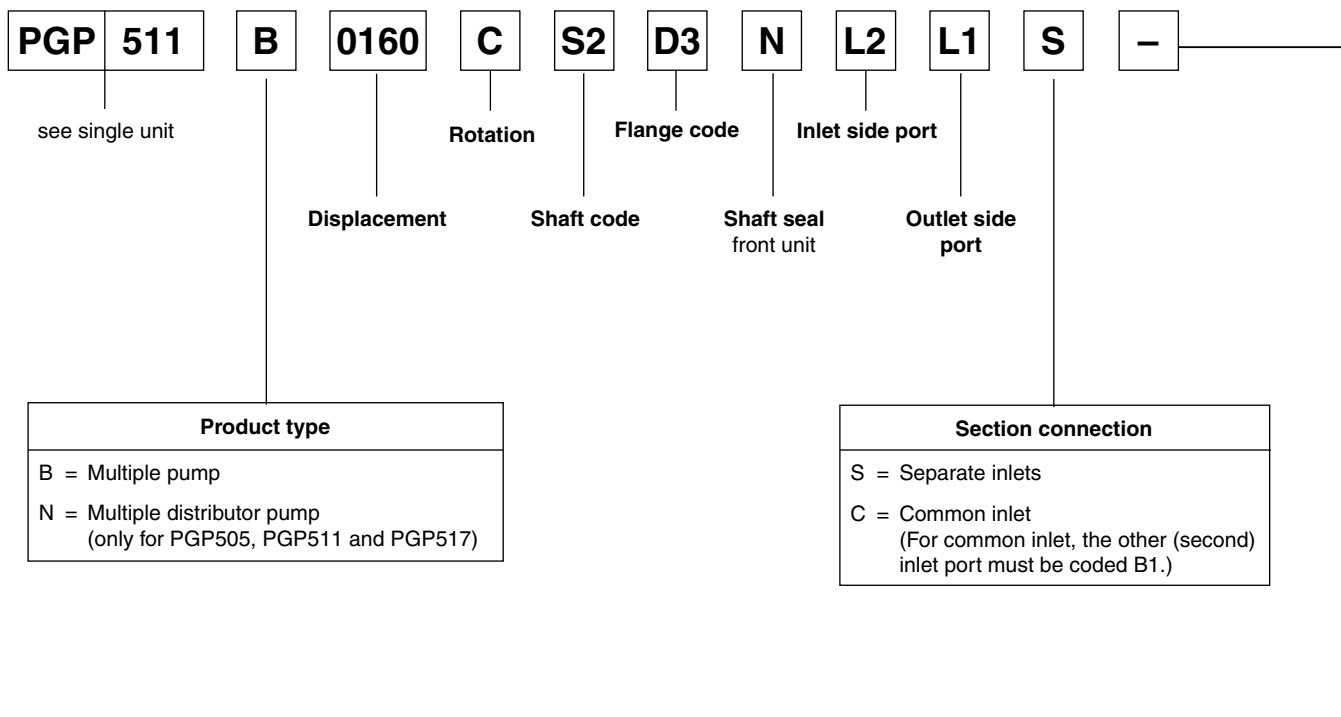

This coding system can be used for all pumps series 500.

Over many years Parker Hydraulics has supplied gear pumps and motors for mobile and industrial markets worldwide, especially for materials handling, commercial grass cutting and construction equipment applications. Many Parker pumps and motors have been developed and tested for the specific needs of these industries.

Parker's defined strategy to provide engineered solutions, coupled with an award winning flexible manufacturing system, has resulted in a wide range of SAE/DIN/European and other special options being available as standard.



Features

- Patented interlocking body design
- 12 tooth gears, bronze balance plates
- Tandem, triple and cross-frame pumps available
- Common inlets available for tandem and triple pumps
- Continuous operating pressures up to 310 bar
- Production run-in available to suite OEM application conditions and to provide optimized volumetric efficiencies
- Pressure balanced design for high efficiency
- Reduced system noise levels compared to earlier models
- High power through-drive capability
- Wide range of integral valves for power steering, power brakes, fan drivers and implement hydraulics
- Load sense and solenoid operated unloading valves
- Low noise version as "stealth" pump

Technical data

Pump type	Heavy-duty, cast iron, external gear.
Mounting	SAE, rectangular, thru-bolt standard specials on request.
Ports	SAE and metric split flanges and others
Shaft style	SAE splined, keyed, tapered, cylindrical tang drive, specials on request.
Speed	500 - 3500 rpm, see Technical Data
Theor. displacement	See Technical Data
Drive	Drive direct with flexible coupling is recommended.
Axial / Radial load	Units subject to axial or radial loads must be specified with an outboard bearing.
Inlet pressure	Operating range 0.8 to 2 bar abs. Min. inlet pressure 0.5 bar abs. Short time without load. Consultation is recommended.
Outlet pressure	See Technical Data
Pressure rising rate	Max. 3000 bar/s
Flow velocity	See Nomograph for Pipe Velocity
Hydraulic fluids	Hydraulic oil HLP, DIN 51524-2
Fluid temperature	Range of operating temperature -15 to +80 °C. Max. permissible operating pressure dependent on fluid temperature. Temperature for cold start -20 to -15 °C at speed ≤ 1500 rpm. Max. permissible operating pressure dependent on fluid temperature.

Fluid viscosity	Range of operating viscosity 8 to 1000 mm ² /s. Max. permissible operating pressure dependent on viscosity. Viscosity range for cold start 1000 to 2000 mm ² /s at operating pressure p ≤ 10 bar and speed n ≤ 1500 rpm.
Range of ambient temperature	-40 °C to +70 °C
Filtration	According to ISO 4406 Cl. 18/16/13
Direction of rotation (looking at the drive shaft)	Clockwise, counter-clockwise or double. Attention! Drive pump only in indicated direction of rotation.
Multiple pump assemblies	<ul style="list-style-type: none"> • Available in two or three section configuration. • Max. shaft load must be conform to the limitations shown in the shaft loading rating table in this catalogue. • Max. load is determined by adding the torque values for each pumping section that will be simultaneously loaded.
Separate or common inlet capability	Separate inlet configuration: <ul style="list-style-type: none"> • Each gear housing has individual inlet and outlet ports. Common inlet configuration: <ul style="list-style-type: none"> • Two gear sets share a common inlet.

PI PGP-PGM UK.PMD RH

PGP620 - 16.0 CC

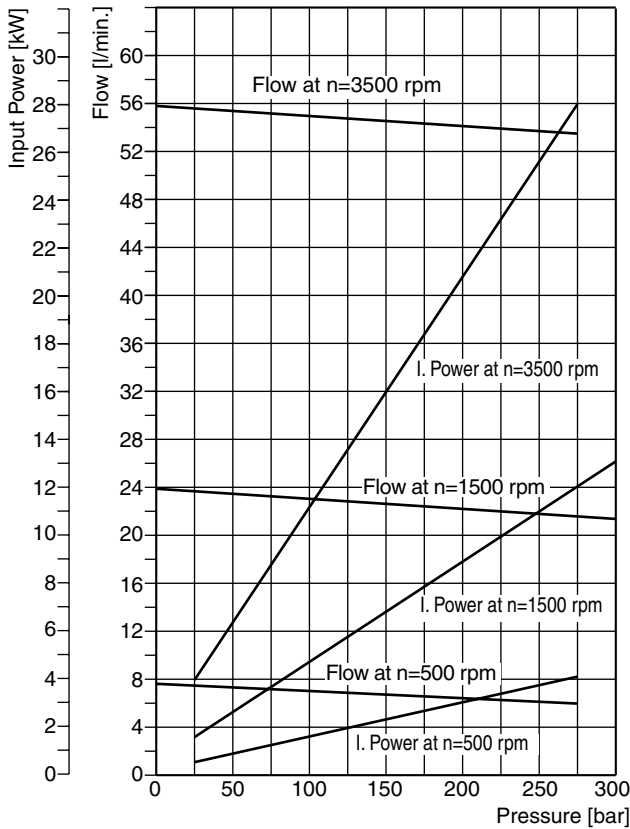

PGP620 - 26.0 CC

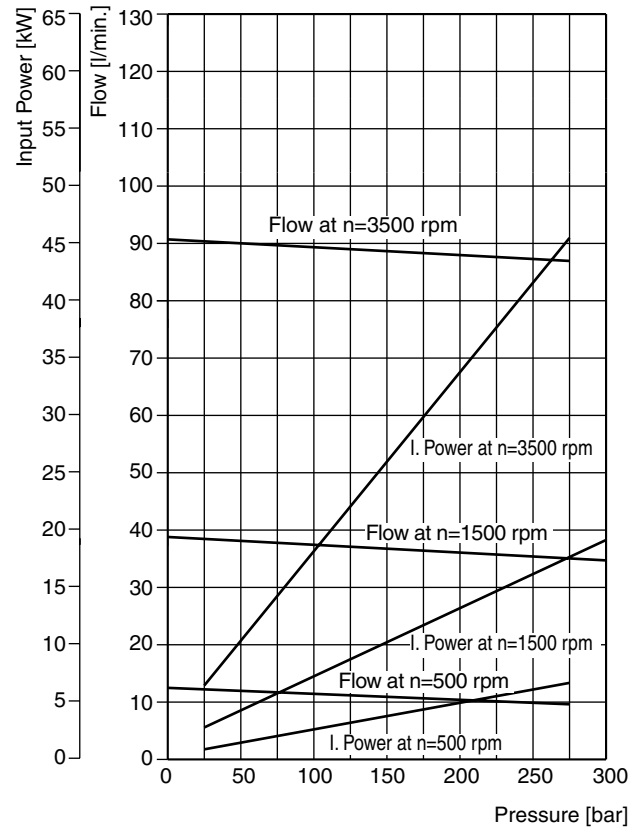

PGP620 - 41.0 CC

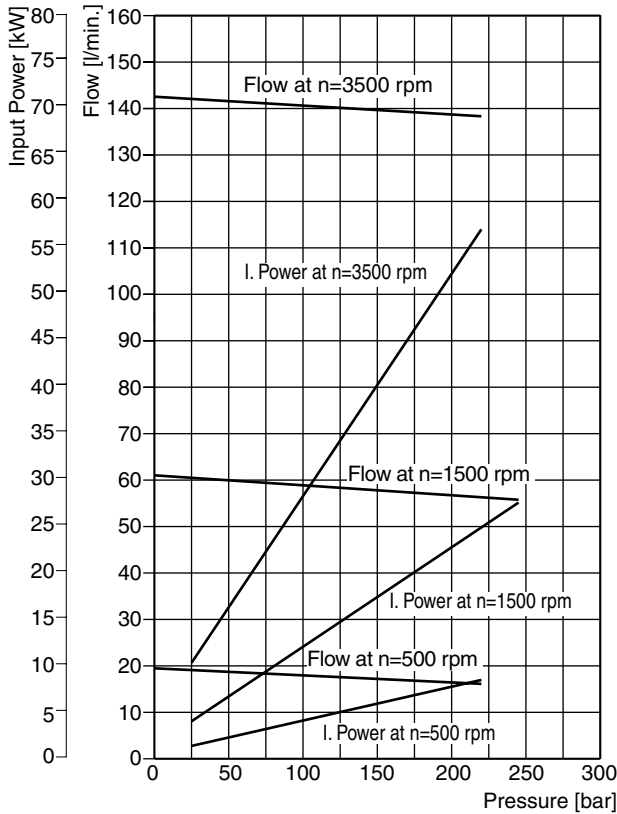

PGP620 - 52.0 CC

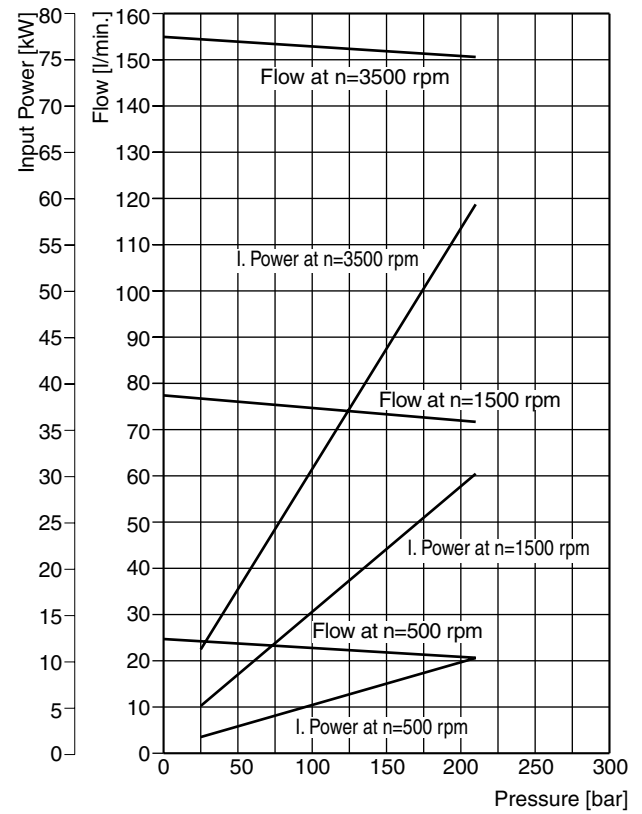

Fluid temperature: 45 °C ± 2K ; Viscosity: 36mm²/s ; Inlet pressure: 0.9 + 0.1 bar absolute

PI PGP-PGM UK.PMD RH



PGP620 A XXXX Y D1 H3 N SS PP B1 B1

“Y” = C (clockwise rotation)
 = A (counter-clockwise rotation)

Displacement XXXX	cm ³ /rev	Dimension		Inlet port		Outlet port		Speed of rotation		Working pressure max. bar	Order number direction of rotation	
		A	B	SS	G	PP	G	min. rpm	max. rpm		clockwise	counter-clockwise
0160	16.0	79.2	122.7	E6	1"-11	E5	¾"-14	500	3000	275	702 9111 052	702 9112 053
0190	19.0	82.5	126.0	E6	1"-11	E5	¾"-14	500	3000	275	702 9111 186	
0210	21.0	84.7	128.2	E6	1"-11	E5	¾"-14	500	3000	275	702 9111 168	
0230	23.0	86.9	130.4	E6	1"-11	E5	¾"-14	500	2700	275	702 9111 098	702 9112 054
0260	26.0	90.2	133.7	E6	1"-11	E5	¾"-14	500	2400	275	702 9111 112	702 9112 093
0290	29.0	93.5	137.0	E7	1¼"-11	E5	¾"-14	500	3000	275		
0330	33.0	97.9	141.4	E7	1¼"-11	E5	¾"-14	500	3000	275		
0360	36.0	101.2	144.7	E7	1¼"-11	E5	¾"-14	500	2900	250		
0370	37.0	102.3	145.8	E7	1¼"-11	E5	¾"-14	500	2900	250	702 9111 164	702 9112 046
0410	41.0	106.7	150.2	E7	1¼"-11	E5	¾"-14	500	2600	220		702 9112 071
0440	44.0	110.0	153.5	E8	1½"-11	E6	1"-11	500	3000	210		702 9112 105
0460	46.0	112.2	155.7	E8	1½"-11	E6	1"-11	500	3000	210		
0500	50.0	116.6	160.1	E8	1½"-11	E6	1"-11	500	3000	210		
0520	52.0	118.8	162.3	E8	1½"-11	E6	1"-11	500	3000	210		702 9112 104

Dimensions (clockwise rotation shown)

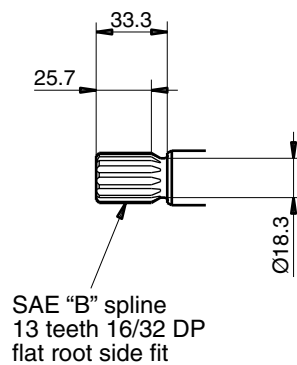
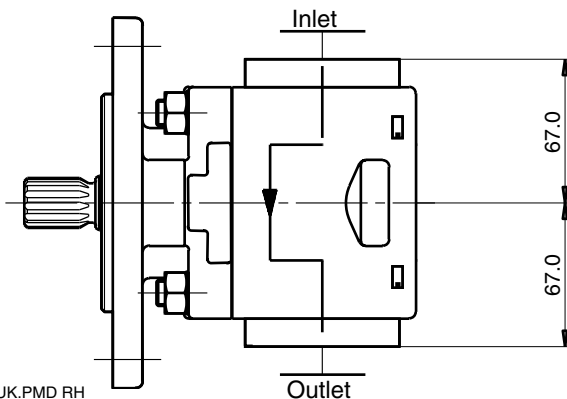
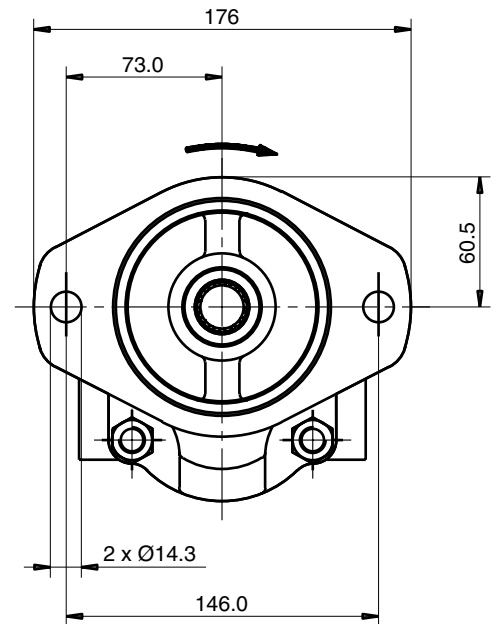
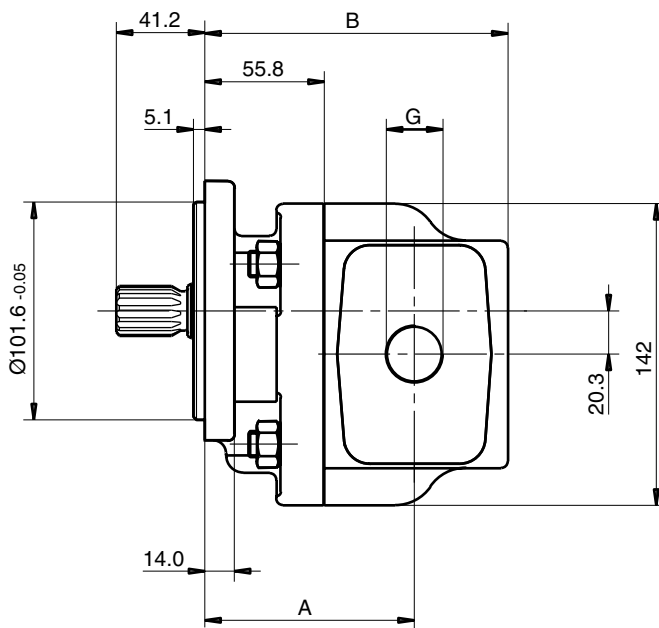
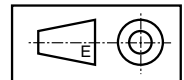

PI PGP-PGM UK.PMD RH



PGP620 A XXXX Y T1 D7 N SS PP B1 B1

“Y” = C (clockwise rotation)
 = A (counter-clockwise rotation)

Displacement XXXX	cm ³ / rev	Dimension		Inlet port					Outlet port					Speed of rotation		Working pressure max. bar	Order number direction of rotation	
		A	B	SS	d	G	H	W	SS	d	G	H rpm	W rpm	min.	max.		clockwise	counter-clockw.
0160	16	79.2	122.7	T3	1"	M10	52.37	26.19	T2	¾"	M10	47.63	22.23	500	1500	275		
0190	19	82.5	126.0	T3	1"	M10	52.37	26.19	T2	¾"	M10	47.63	22.23	500	2300	275		702 9112 062
0210	21	84.7	128.2	T3	1"	M10	52.37	26.19	T2	¾"	M10	47.63	22.23	500	2000	275		
0230	23	86.9	130.4	T3	1"	M10	52.37	26.19	T2	¾"	M10	47.63	22.23	500	1900	275		
0260	26	90.2	133.7	T4	1¼"	M10	58.72	30.17	T3	1"	M10	52.37	26.19	500	1600	275		
0290	29	93.5	137.0	T4	1¼"	M10	58.72	30.17	T3	1"	M10	52.37	26.19	500	3000	275	702 9111 151	
0330	33	97.9	141.4	T4	1¼"	M10	58.72	30.17	T3	1"	M10	52.37	26.19	500	2600	275	702 9111 087	702 9112 070
0360	36	101.2	144.7	T4	1¼"	M10	58.72	30.17	T3	1"	M10	52.37	26.19	500	2400	250		
0370	37	102.3	145.8	T4	1¼"	M10	58.72	30.17	T3	1"	M10	52.37	26.19	500	2300	250		
0410	41	106.7	150.2	T5	1½"	M12	69.82	35.71	T3	1"	M10	52.37	26.19	500	2100	220	702 9111 179	702 9112 117
0440	44	110.0	153.5	T5	1½"	M12	69.82	35.71	T3	1"	M10	52.37	26.19	500	2000	210		702 9112 037
0460	46	112.2	155.7	T5	1½"	M12	69.82	35.71	T3	1"	M10	52.37	26.19	500	1900	210	702 9111 117	
0500	50	116.6	160.1	T5	1½"	M12	69.82	35.71	T3	1"	M10	52.37	26.19	500	1700	210	702 9111 150	
0520	52	118.8	162.3	T5	1½"	M12	69.82	35.71	T3	1"	M10	52.37	26.19	500	1700	210		702 9112 022

Dimensions (clockwise rotation shown)

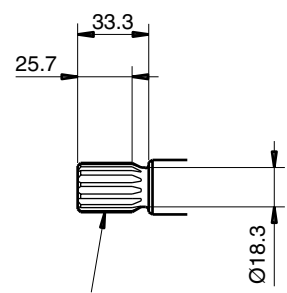
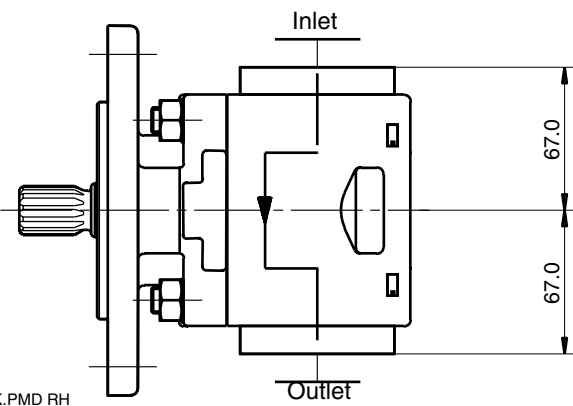
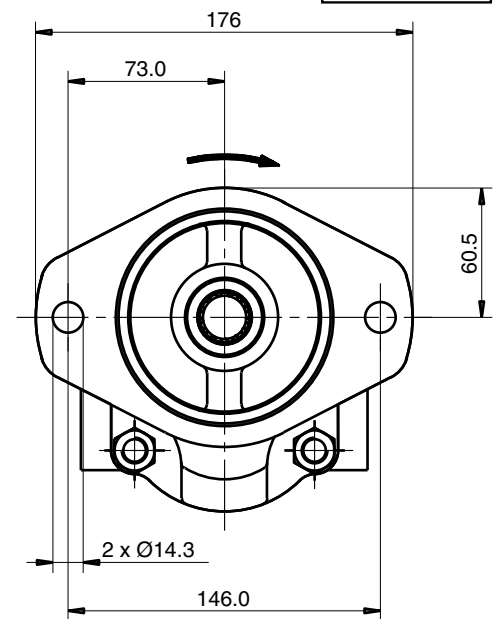
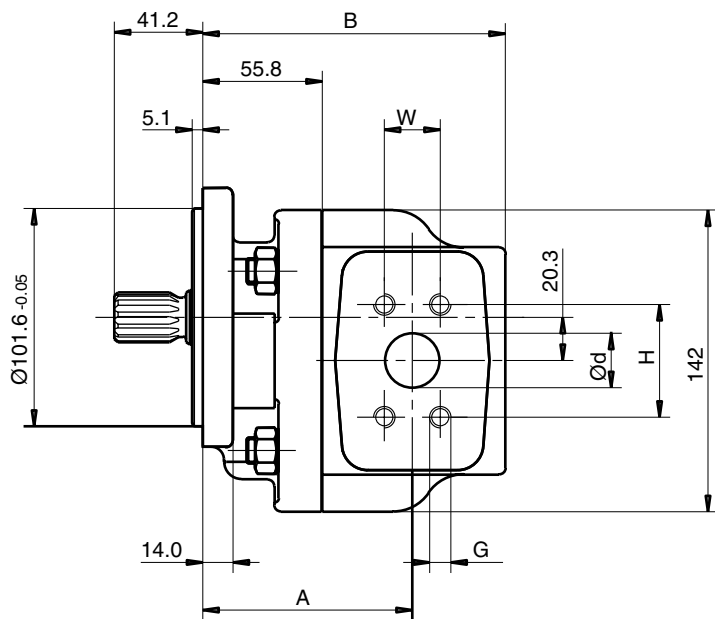
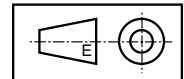

SAE "B" spline
 13 teeth 16/32 DP
 flat root side fit

PI PGP-PGM UK.PMD RH





Gear design	Type
Code	Type
P	Pump
M	Motor

Code	Unit	
	Pump	Motor
A	Single unit	Standard motor with drain port
B	Multiple unit	Standard motor w. two checks
C	—	Standard motor w. one anti-cavitation check (ACC)

Displacement	
Code	ccm
0300	30.0
0350	35.0
0400	40.0
0450	45.0
0500	50.0
0550	55.0
0600	60.0
0650	65.0
0700	70.0
0750	75.0
0800	80.0

Code	Rotation
C	Clockwise
A	Counter-clockwise
B	Bi-directional

Code	Shaft
D1 ²⁾	13T, 16/32DP, 41.2L, SAE "B" spline
E1 ²⁾	15T, 16/32DP, 46.0L, SAE "B-B" spline
E4 ³⁾	14T, 12/24DP, 55.6L, SAE "C" spline

²⁾ Only used with flange A3, H3.
³⁾ Only used with flange A4, K3.

Code	Port options (pumps)
E8E7	1½" -11 BSP Thread / 1¼" -11 BSP Thread rec. from 30 ccm to 50 ccm
T4T3	1¼" - M10 SAE metr. split flange 1" - M10 SAE split flange rec. from 30 ccm to 40 ccm
T5T3	1½" - M12 SAE metr. split flange 1" - M10 SAE split flange rec. from 45 ccm to 60 ccm
T6T4	2" - M12 SAE metr. split flange 1¼" - M10 SAE metr. split flange rec. from 65 ccm to 80 ccm
Code	Port options (motors)
E7E7	1¼"-11 BSP thread/ 1¼"-11 BSP thread

Example: T5 = inlet port
T3 = outlet port

Code	Shaft seal
X	No seal
N	NBR
V	FPM
T	PTFE (motors only)

Code	Flange
A3	89.8x89.8 - Ø101.06 4 bolt square flange
A4	114.5x114.5 - Ø127 SAE "C" 4 bolt square flange
H3	146.1 - Ø101.06 SAE "B" 2 bolt flange
K3	181.0 - Ø127 SAE "C" 2 bolt flange

¹⁾ Code of drain line for PGM640 only.
2 Options:
G4 = 1/4"-19 BSP rear drain.
B1 = no drain, unit code must be "B" or "C".



PGP640 - 30.0 CC

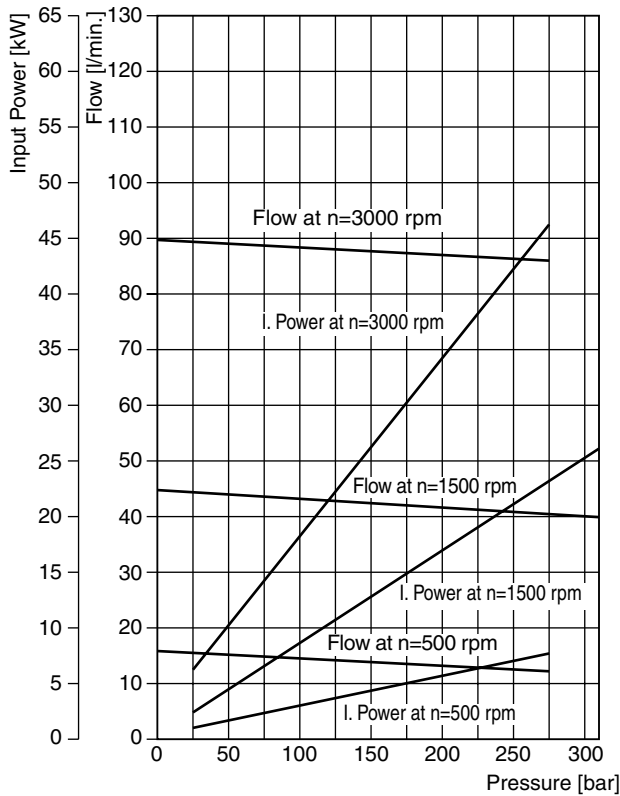

PGP640 - 50.0 CC

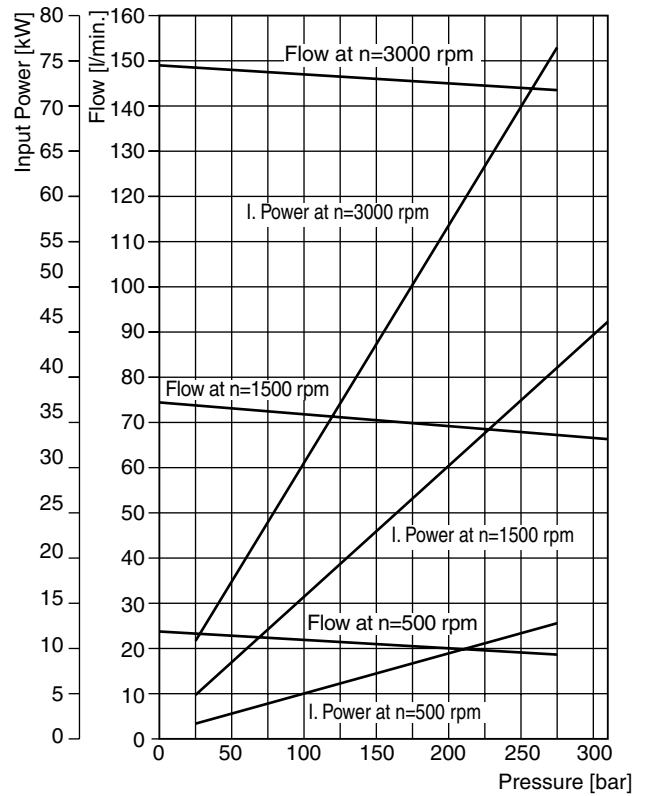

PGP640 - 65.0 CC

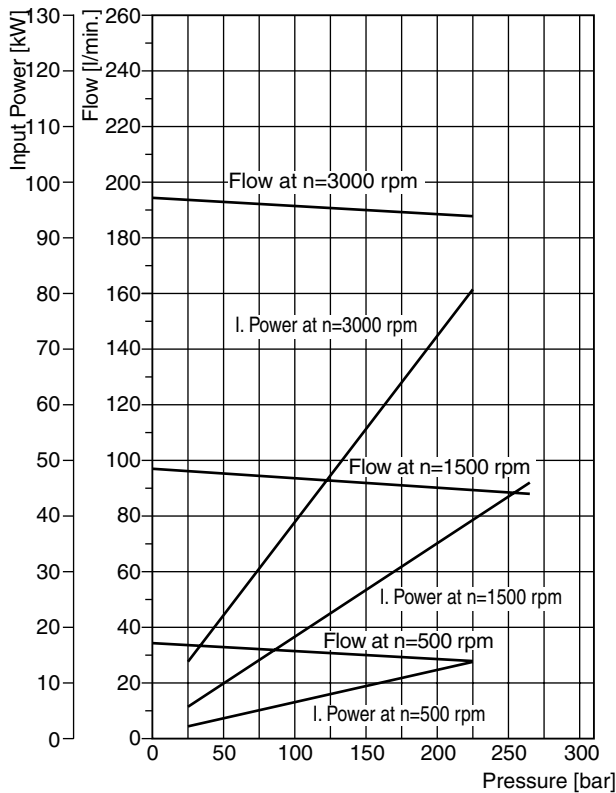

PGP640 - 80.0 CC

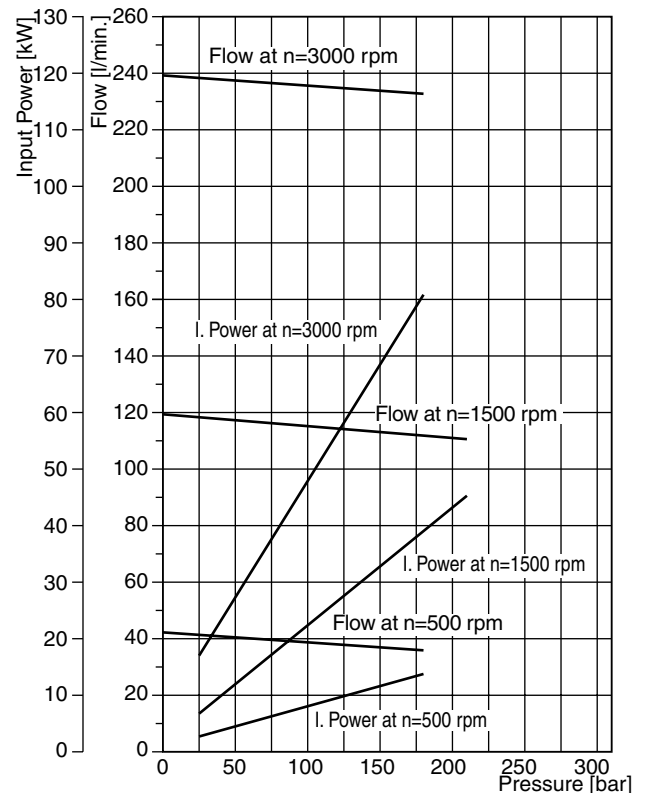

Fluid temperature: 45 °C ± 2K ; Viscosity: 36mm²/s ; Inlet pressure: 0.9 + 0.1 bar absolute

PI PGP-PGM UK.PMD RH



PGP640 A XXXX Y D1 H3 N SS PP B1 B1

“Y” = C (clockwise rotation)
 = A (counter-clockwise rotation)

Displacement XXXX cm ³ / rev	Dimension		Inlet port					Outlet port					Speed of rotation		Working pressure max. bar	Order number direction of rotation		
	A	B	SS	d	G	H	W	PP	d	G	H	W	min. rpm	max. rpm		clockwise	counter-clockwise	
0300	30	128.6	176.1	T4	1-¼"	M10	58.72	30.17	T3	1"	M10	52.37	26.19	500	3000	310		
0350	35	128.6	176.1	T4	1-¼"	M10	58.72	30.17	T3	1"	M10	52.37	26.19	500	3000	310		
0400	40	131.8	182.7	T4	1-¼"	M10	58.72	30.17	T3	1"	M10	52.37	26.19	500	3000	310	704 9111 055	704 9112 020
0450	45	131.8	182.7	T5	1-½"	M12	69.82	35.71	T3	1"	M10	52.37	26.19	500	3000	310		
0500	50	135.6	189.3	T5	1-½"	M12	69.82	35.71	T3	1"	M10	52.37	26.19	500	3000	310	704 9111 016	
0550	55	135.6	189.3	T5	1-½"	M12	69.82	35.71	T3	1"	M10	52.37	26.19	500	3000	310	704 9111 050	704 9112 019
0600	60	138.4	195.8	T5	1-½"	M12	69.82	35.71	T3	1"	M10	52.37	26.19	500	3000	290	704 9111 059	
0650	65	138.4	195.8	T6	2"	M12	77.77	42.88	T4	1-¼"	M10	58.72	30.17	500	3000	265	704 9111 040	704 9112 022
0700	70	142.2	203.2	T6	2"	M12	77.77	42.88	T4	1-¼"	M10	58.72	30.17	500	3000	245		
0750	75	142.2	203.2	T6	2"	M12	77.77	42.88	T4	1-¼"	M10	58.72	30.17	500	3000	225		
0800	80	142.2	203.2	T6	2"	M12	77.77	42.88	T4	1-¼"	M10	58.72	30.17	500	3000	210	704 9111 045	

Dimensions (clockwise rotation shown)

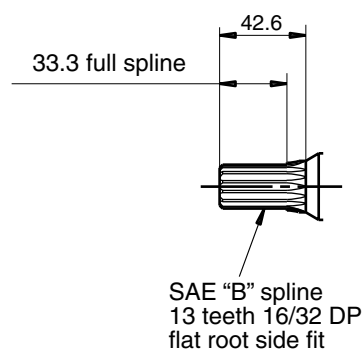
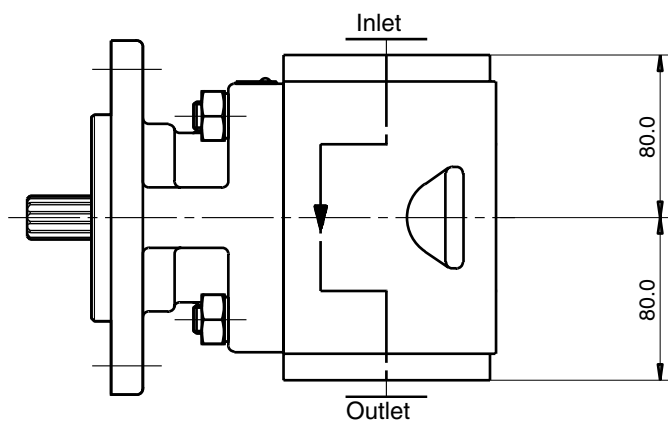
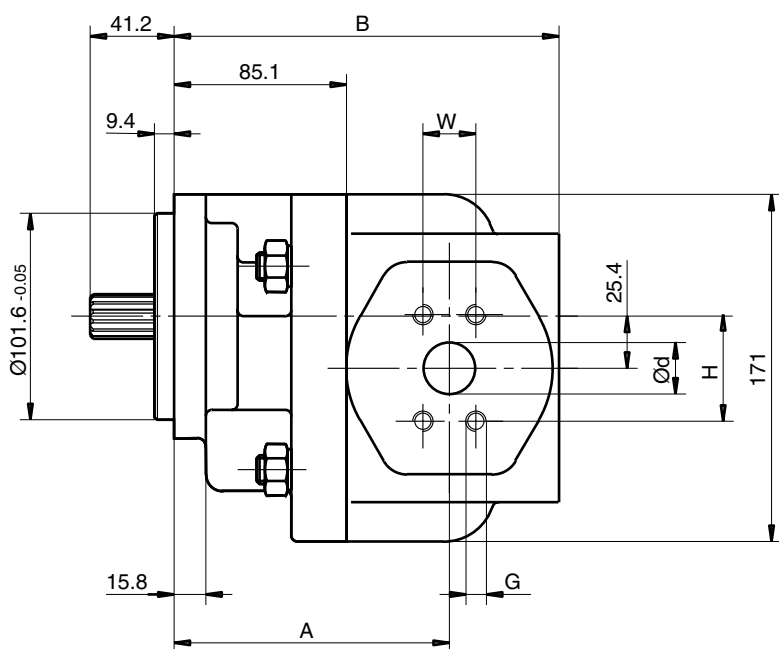
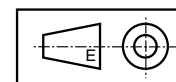

PI PGP-PGM UK.PMD RH



Code for multiple units

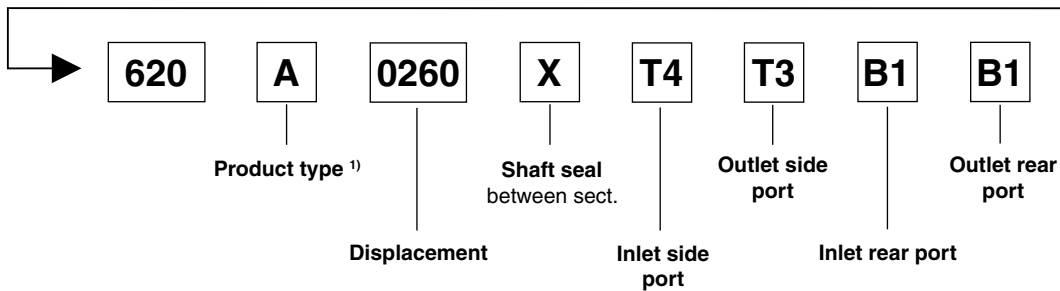
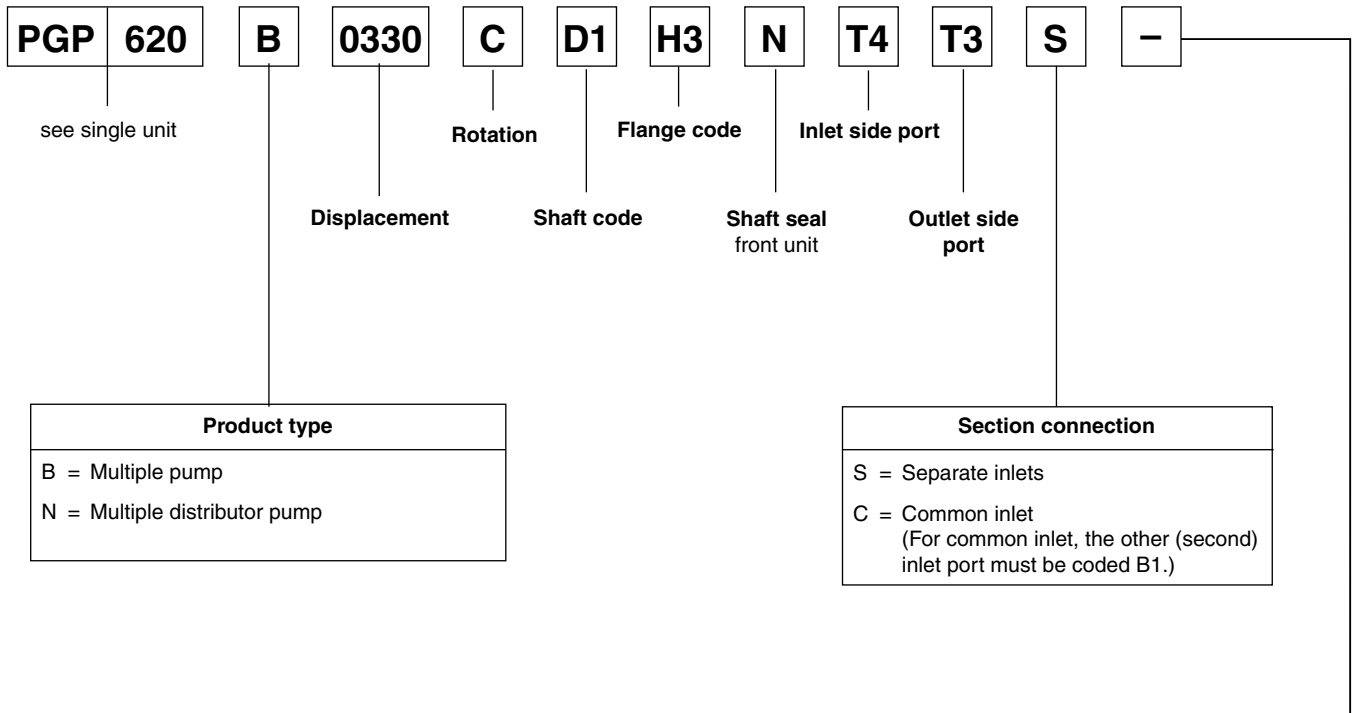

¹⁾ Further B possible for triple units

This coding system can be used for all pumps series 600.

Quality pays

Aluminium or cast-iron bodied 'split-gear' gear pumps are designed for high pressure and speed ratings together with high efficiency and optimised noise levels.

The flow pulsation is considerably decreased by phased dual element gear sets, resulting in models with clearly lower noise levels. Common inlet available for multiple section units.

Series PGP511 / PGP620 (on request)

- Up to 250 bar constant operation possible due to high-quality materials
- Low noise levels even in constant operation
- High efficiency thanks to precise manufacturing
- Complete product range for huge variety of applications
- Common inlet ports for double and triple pumps
- Wide choice of integrated valves, e.g. load-sensing and solenoid types
- Full range of proven motors available

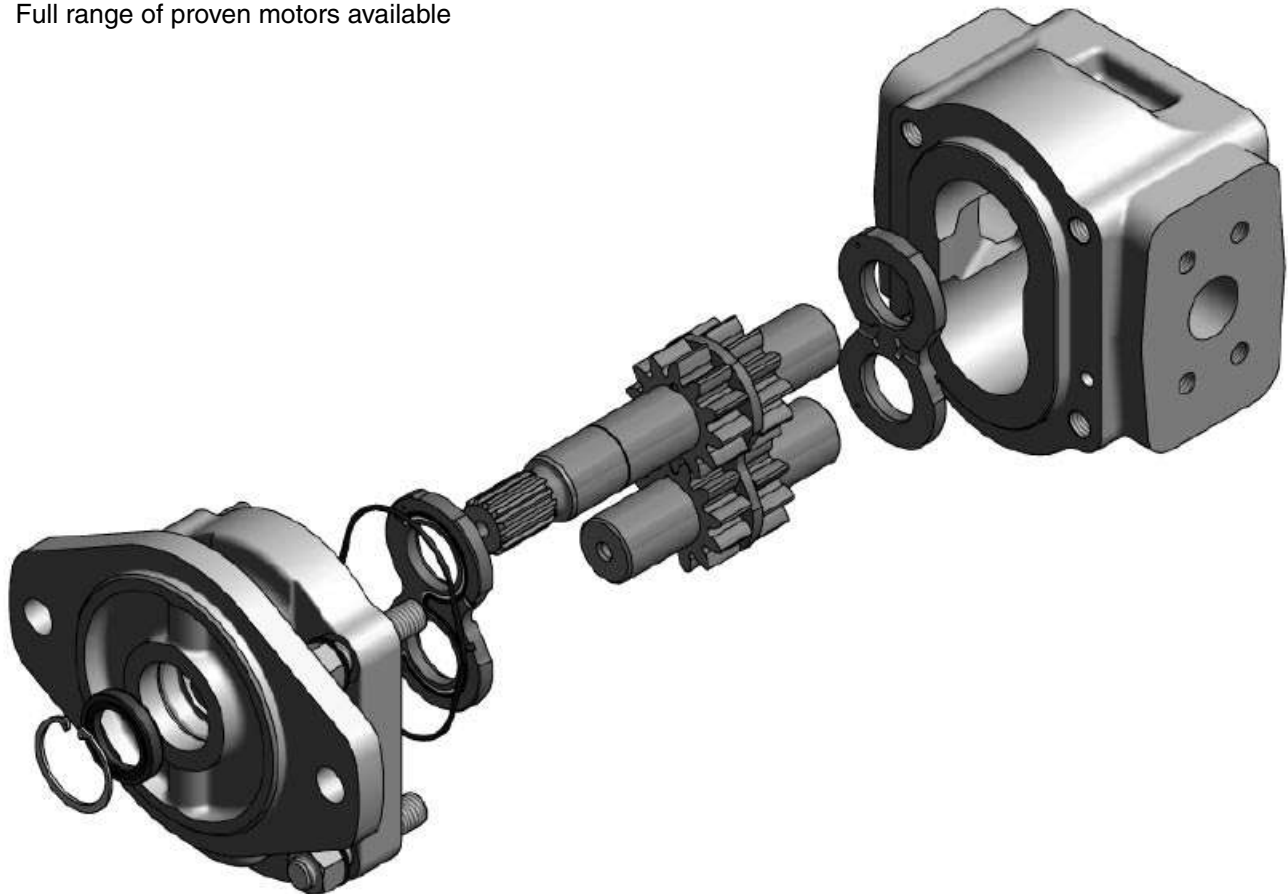

Nomograph for Pipe Velocity

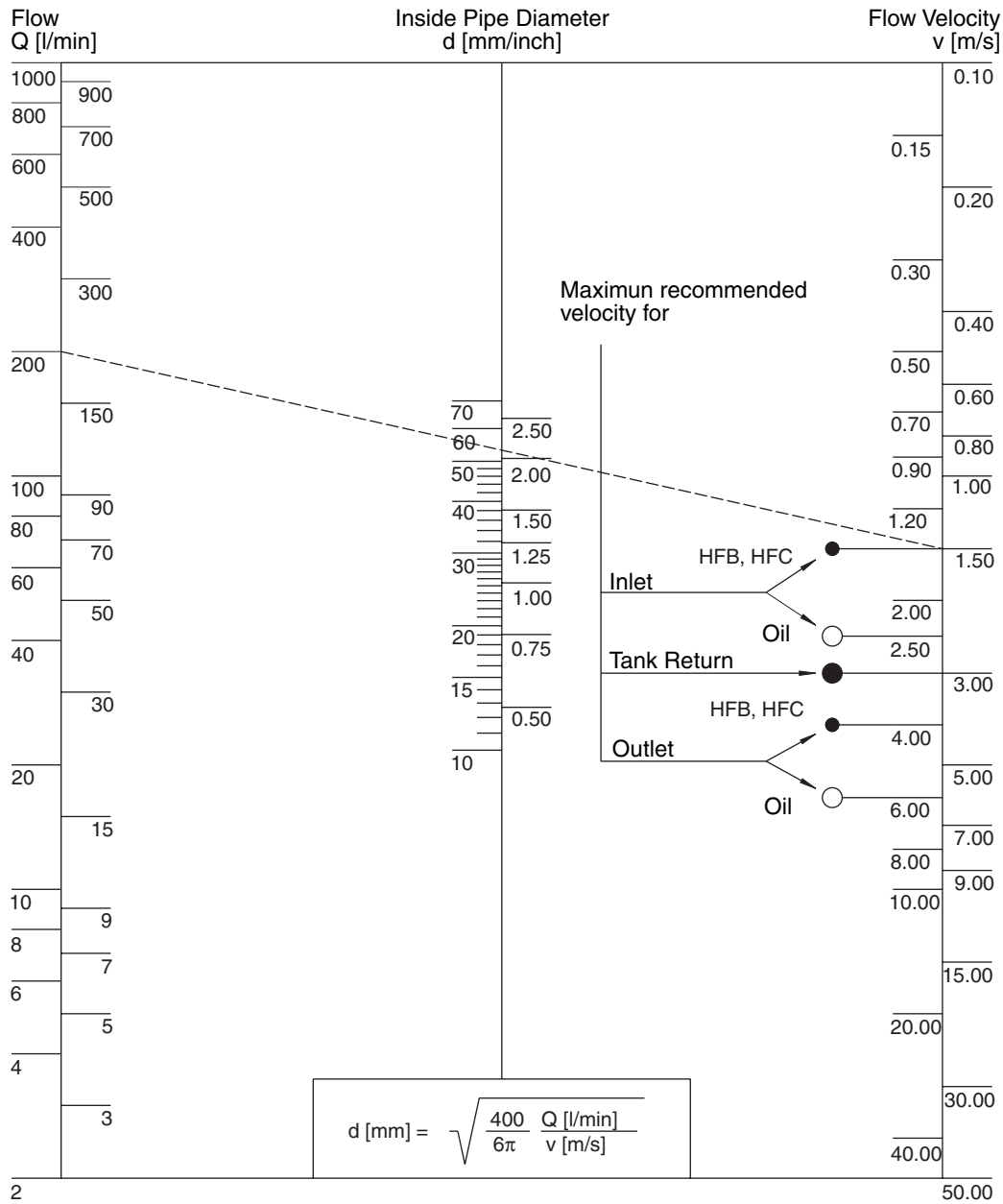

Shaft loads PGP/PGM500

Code	Description	Type	Torque rating [Nm]			
			PGP/PGM503	PGP/PGM505	PGP/PGM511	PGP/PGM517
H1	Ø10.0, 3.0 key, no thread, 36L	parallel	30	—	—	—
P2	Ø9.95, 8.8L, 2.4 key, M6	taper 1:8	30	—	—	—
V1	5 x 6.5 long shaft w/o coupling	tang drive	20	—	—	—
V2	5 x 4.5 short shaft w/o coupling	tang drive	20	—	—	—
A1	9T, 16/32DP, 32L, SAE "A"	splined	—	108	—	—
J1	Ø12.7, 3.2 key, no thread, 38L	parallel	—	43	—	—
K1	Ø15.88, 4.0 key, no thread, 32L, SAE "A"	parallel	—	85	—	—
Q2	Ø14.25, 5.5L, 3.0 key, M10x1	taper 1:8	—	68	—	—
A1	9T, 16/32DP, 32L, SAE "A"	splined	—	—	86	—
C1	11T, 16/32DP, 38.2L, SAE 19-4	splined	—	—	184	—
F1	9T, B17x14.23L, DIN 5482	splined	—	—	101	—
K1	Ø15.88, 4.0 key, no thread, 32L, SAE "A"	parallel	—	—	75	—
L6	Ø19.05, 4.8 key, no thread, 32L, SAE 19-1	parallel	—	—	145	—
S1	Ø17.0, 7.7L, 3.0 key, M12x1.5	taper 1:5	—	—	193	—
S2	Ø16.65, 12.0L, 3.2 key, M12x1.5	taper 1:8	—	—	198	—
S4	Ø16.65, 12.0L, 4.0 key, M12x1.5	taper 1:8	—	—	198	—
D1	13T, 16/32DP, 41.2L, SAE "B"	splined	—	—	—	345
M1	Ø22.2, 6.3 key, no thread, 41.2L, SAE "B"	parallel	—	—	—	251
M2	Ø25.4, 6.3 key, no thread, 46L, SAE "B-B"	parallel	—	—	—	395
T1	Ø21.59, 11.2L, 4.0 key, M14x1.5	taper 1:8	—	—	—	250
	Connecting shaft for multiple units		20	36	110	228

Shaft loads PGP/PGM600

Code	Description	Type	Torque rating 620 [Nm]	Torque rating 640 [Nm]
D1	13T, 16/32 DP, 41.2L, SAE "B"	splined	272	328
E1	15T, 16/32 DP, 46.0L, SAE "B-B"	splined	460	503
E4	14T, 12/24 DP, 5.6L, SAE "C"	splined	—	960
T1	Ø21.59, 11.2L, 4.0key, M14x1.5	tapered 1:8	218	—
	Connecting shaft for multiple units		228	407

Formula to calculate shaft load

$$\text{Torque [Nm]} = \frac{\text{Displacement [cm}^3\text{/rev]} \cdot \text{Pressure [bar]}}{57.2}$$

Hydraulic fluids

Type	Fluid composition	Max. working pressure [bar]	Max. speed [min ⁻¹]	Temperature	Seal
Hydraulic fluid	Mineral oil based on hydraulic fluid acc. to ISO/DIN	See Technical Data	See Technical Data	-15 ... +80°C -15 ... +120°C	NBR FPM
HFB	Water-in-oil emulsion 40/60	140	1500	+2 ... +65°C	NBR
HFC	Water-glycol 40/60	140	1500	-15 ... +65°C	NBR
HFD	Phosphate ester	140	1500	-10 ... +80°C	FPM

Flanges for suction and discharge ports

Please refer to Parker Bulletin 4040/UK.

Parker Worldwide

AE – UAE, Dubai
Tel: +971 4 8127100
parker.me@parker.com

AR – Argentina, Buenos Aires
Tel: +54 3327 44 4129

AT – Austria, Wiener Neustadt
Tel: +43 (0)2622 23501-0
parker.austria@parker.com

AT – Eastern Europe, Wiener Neustadt
Tel: +43 (0)2622 23501 970
parker.easteurope@parker.com

AU – Australia, Castle Hill
Tel: +61 (0)2-9634 7777

AZ – Azerbaijan, Baku
Tel: +994 50 2233 458
parker.azerbaijan@parker.com

BE/LU – Belgium, Nivelles
Tel: +32 (0)67 280 900
parker.belgium@parker.com

BR – Brazil, Cachoeirinha RS
Tel: +55 51 3470 9144

BY – Belarus, Minsk
Tel: +375 17 209 9399
parker.belarus@parker.com

CA – Canada, Milton, Ontario
Tel: +1 905 693 3000

CH – Switzerland, Etoy
Tel: +41 (0) 21 821 02 30
parker.switzerland@parker.com

CN – China, Shanghai
Tel: +86 21 5031 2525

CZ – Czech Republic, Klecany
Tel: +420 284 083 111
parker.czechrepublic@parker.com

DE – Germany, Kaarst
Tel: +49 (0)2131 4016 0
parker.germany@parker.com

DK – Denmark, Ballerup
Tel: +45 43 56 04 00
parker.denmark@parker.com

ES – Spain, Madrid
Tel: +34 902 33 00 01
parker.spain@parker.com

FI – Finland, Vantaa
Tel: +358 (0)20 753 2500
parker.finland@parker.com

FR – France, Contamine s/Arve
Tel: +33 (0)4 50 25 80 25
parker.france@parker.com

GR – Greece, Athens
Tel: +30 210 933 6450
parker.greece@parker.com

HK – Hong Kong
Tel: +852 2428 8008

HU – Hungary, Budapest
Tel: +36 1 220 4155
parker.hungary@parker.com

IE – Ireland, Dublin
Tel: +353 (0)1 466 6370
parker.ireland@parker.com

IN – India, Mumbai
Tel: +91 22 6513 7081-85

IT – Italy, Corsico (MI)
Tel: +39 02 45 19 21
parker.italy@parker.com

JP – Japan, Fujisawa
Tel: +(81) 4 6635 3050

KR – South Korea, Seoul
Tel: +82 2 559 0400

KZ – Kazakhstan, Almaty
Tel: +7 7272 505 800
parker.easteurope@parker.com

LV – Latvia, Riga
Tel: +371 6 745 2601
parker.latvia@parker.com

MX – Mexico, Apodaca
Tel: +52 81 8156 6000

MY – Malaysia, Subang Jaya
Tel: +60 3 5638 1476

NL – The Netherlands, Oldenzaal
Tel: +31 (0)541 585 000
parker.nl@parker.com

NO – Norway, Ski
Tel: +47 64 91 10 00
parker.norway@parker.com

NZ – New Zealand, Mt Wellington
Tel: +64 9 574 1744

PL – Poland, Warsaw
Tel: +48 (0)22 573 24 00
parker.poland@parker.com

PT – Portugal, Leca da Palmeira
Tel: +351 22 999 7360
parker.portugal@parker.com

RO – Romania, Bucharest
Tel: +40 21 252 1382
parker.romania@parker.com

RU – Russia, Moscow
Tel: +7 495 645-2156
parker.russia@parker.com

SE – Sweden, Spånga
Tel: +46 (0)8 59 79 50 00
parker.sweden@parker.com

SG – Singapore
Tel: +65 6887 6300

SK – Slovakia, Banská Bystrica
Tel: +421 484 162 252
parker.slovakia@parker.com

SL – Slovenia, Novo Mesto
Tel: +386 7 337 6650
parker.slovenia@parker.com

TH – Thailand, Bangkok
Tel: +662 717 8140

TR – Turkey, Istanbul
Tel: +90 216 4997081
parker.turkey@parker.com

TW – Taiwan, Taipei
Tel: +886 2 2298 8987

UA – Ukraine, Kiev
Tel +380 44 494 2731
parker.ukraine@parker.com

UK – United Kingdom, Warwick
Tel: +44 (0)1926 317 878
parker.uk@parker.com

US – USA, Cleveland (industrial)
Tel: +1 216 896 3000

US – USA, Lincolnshire (mobile)
Tel: +1 847 821 1500

VE – Venezuela, Caracas
Tel: +58 212 238 5422

ZA – South Africa, Kempton Park
Tel: +27 (0)11 961 0700
parker.southafrica@parker.com

European Product Information Centre
Free phone: 00 800 27 27 5374
(from AT, BE, CH, CZ, DE, EE, ES, FI, FR, IE, IT, PT, SE, SK, UK)



Parker Hannifin Ltd.
Tachbrook Park Drive
Tachbrook Park, Warwick CV34 6TU
United Kingdom
Tel.: +44 (0) 1926 317 878
Fax: +44 (0) 1926 317 855
www.parker.com